

uptime[®]

for reliability leaders and asset managers

feb/mar 19



“I love disconnected data.”

— said no one ever

Learn more: [fluke.com/reliability](https://www.fluke.com/reliability)

©2019 Fluke Corporation. 01/2019 6011909a-en

Connected Reliability bridges the gaps between assets, systems, and people. Do more with your data.

FLUKE®

The **RELIABILITY** Conference™

Co-located with
Maintenance 4.0
Digitalization Forum



MAY 6-10, 2019 • Seattle, Washington

SAVE
\$200

Valid thru February 28, 2019.

reliabilityconference.com

A Reliabilityweb.com® and Uptime® Magazine Event



RON MOORE

Receives Award from Reliabilityweb.com



Reliabilityweb.com honored Ron Moore with the Lifetime Achievement Award for his contribution to the industry at the International Maintenance Conference (IMC-2018), December 12, in beautiful Bonita Springs, Florida. A self-proclaimed "hillbilly," Ron is an internationally recognized authority on strategies and practices for manufacturing and operational excellence. His work has touched thousands and has reached around the world to companies big and small. As Terrence O'Hanlon stated, "In our community, Ron is our version of Juran. Our version of Deming."

Ron is the author of several books, including *Making Common Sense Common Practice: Models for Operational Excellence*, 5th Edition and *What Tool? When? A Management Guide for Selecting the Right Improvement Tools*. He is currently working on publishing his next book, with the working title, *A Common Sense Approach to Defect Elimination*, due to be released Spring of 2019. For more information: mro-zone.com

Thank you, Ron, for everything you have done for this industry, and from Reliabilityweb.com, thank you for your support and friendship. Congratulations!

BOOKS BY RON MOORE

- *[Making Common Sense Common Practice](#)*
- *[What Tool? When? A Management Guide for Selecting the Right Improvement Tools](#)*
- *[Business Fables & Foibles](#)*
- *[Where Do We Start Our Improvement Program?](#)*

reliabilityweb.com/bookstore





NONE OF US IS AS SMART AS ALL OF US

THERE'S A NEW WAY TO GET RELIABILITY

ROI • VALUES • COMMUNITY • NETWORK • JOURNEY



Reliability Partners Vision:

Advance the industry toward ZERO

• **Accidents** • **Downtime*** • **Waste**

through a holistic reliability framework.

A Powerful Community of **Reliability Partners** to Advance Reliability and Asset Management with You

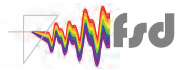

For more information: reliabilityweb.com/directory



*Unplanned

Contents

february/march 2019



uptime[®]
for reliability leaders and
asset managers

ON THE COVER
Can you find the hidden Uptime
logo on the cover? [uptime](#)
magazine

AM

Implementing an Effective Asset Management Process to Improve Reliability
Ramesh Gulati and Terrence O'Hanlon

18

FEATURES

Reliability Leader Feature	
Ron Moore	1
Editorial	5
In the News	6
2018 Uptime Awards	7
Q&A with Industry Leader	
Natasha Ravinand	62

ARTICLES

De Defect Elimination	
10 Steps to Precision Maintenance Reliability Success	
Phil Hendrix and Bill Yantz.....	22

Op Operational Excellence	
Leadership Is Vital to Success	
Roger D. Lee	28

Aci Asset Condition Information	
Emerging Industrial Internet Technology Can Reduce Costs and Dangers in Steam Systems	
Brian Alessi.....	32

AM Asset Management	
Opening the Lid of the Asset Manager's Toolbox, Part 1	
Grahame Fogel and Dean Griffin	36

Vib Vibration Analysis	
Visualizing Flying Horses and Vibrating Machines: Slow-Motion Amplified Video	
Chad Pasho.....	40

Ri Risk Management	
Work Safety, Part 2	
Joel Levitt	44

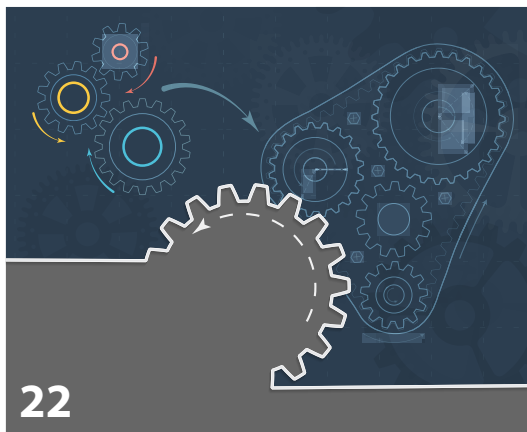

Contents [Continued]

uptime®

CEO/PUBLISHER
Terrence O'Hanlon
terrence@reliabilityweb.com

FOUNDER
Kelly Rigg O'Hanlon

EDITOR
Jenny Brunson

CONTRIBUTING EDITOR

Dave Reiber, Jeff Smith

CONTRIBUTING WRITERS

Brian Alessi, Brett Burger, Bryan Christiansen, Grahame Fogel, Dean Griffin, Ramesh Gulati, Phil Hendrix, Roger D. Lee, Joel Levitt, Ron Moore, Terrence O'Hanlon, Chad Pasho, Natasha Ravinand, Danielle White, Bill Yantz

ASSOCIATE EDITOR

Sean Flack

DESIGNER

Jocelyn Brown

PLANNER AND SCHEDULER

Lisa Imperato

lisa@reliabilityweb.com

SALES & ADVERTISING

Amy Harlan

Client Growth Specialist

amy@reliabilityweb.com

EDITORIAL INFORMATION

Please address submissions of case studies, procedures, practical tips and other correspondence to Terrence O'Hanlon
terrence@reliabilityweb.com

ARTICLE SUBMISSIONS

publishing@reliabilityweb.com

SUBSCRIPTIONS

To subscribe to *Uptime* magazine, log on to

www.uptimemagazine.com

For subscription updates

subscriptions@uptimemagazine.com

Uptime Magazine

8991 Daniels Center Drive, Fort Myers, FL 33912
1-888-575-1245 • 239-333-2500 • Fax: 309-423-7234
www.uptimemagazine.com

Uptime Magazine
is a founding member of



Copyright © 2019, Reliabilityweb.com.
All rights reserved.

No part of Uptime® Magazine may be reproduced or transmitted in any form or by any means without the prior express written consent of Reliabilityweb.com. In the U.S., Uptime® is a registered trademark of Reliabilityweb.com.

Uptime® Magazine (ISSN 1557-0193) is published bimonthly by Reliabilityweb.com, 8991 Daniels Center Drive, Fort Myers, FL 33912, 888-575-1245. Uptime® Magazine is an independently produced publication of Reliabilityweb.com. The opinions expressed herein are not necessarily those of Reliabilityweb.com.

POSTMASTER: Send address changes to:
Uptime® Magazine, 8991 Daniels Center Drive, Fort Myers, FL 33912

Reliabilityweb.com®, Uptime®, RELIABILITY®, A Culture of Reliability®, Certified Reliability Leader®, Reliability Leadership®, Reliability Leadership Institute®, The Reliability Conference®, Reliability for Everyone®, Reliability Framework®, Reliability Leader™ and Reliability Partners™ are registered trademarks or trademarks of Reliabilityweb.com. In the USA and several other countries.

IBM® and Maximo® are registered trademarks of International Business Machines Corporation.

Pm Preventive Maintenance
Technologies That Make Asset Monitoring Boring (In a Good Way)
Brett Burger **48**

OpX Operational Excellence
What Hides Behind the Term: "Lean Maintenance"
Bryan Christiansen **52**

Cr Corporate Responsibility
Choose to Reuse: Environmental Benefits of Reconditioned SF₆
Danielle White **56**



RELIABILITY PARTNERS PAGE 2

A powerful ecosystem of Reliability Partners who support the Uptime Elements Framework.

Banetti	55	Lubrication Engineers.....	Back Cover
Bentley Systems.....	16	LUDECA.....	30, 50
Condition Monitoring International..	54	PRÜFTECHNIK	Inside Back Cover
FLUKE.....	Inside Front Cover	Quartic.ai	17
Hendrix Precision	31	SDMyers.....	59
IRISS.....	64	SDT.....	51
JMS Software	27	Technical Associates of Charlotte.....	43

Uptime® Elements

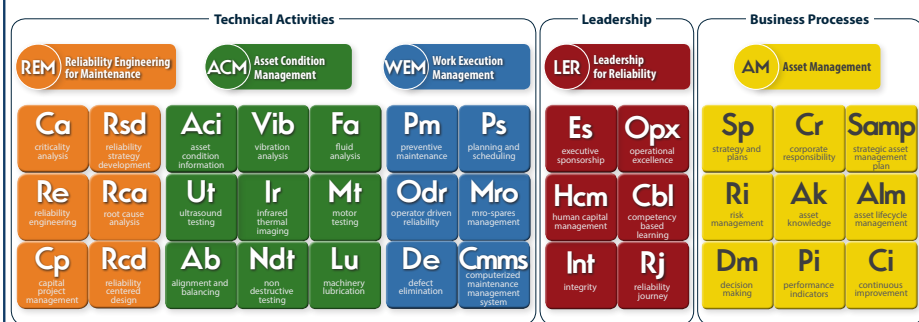

A Reliability Framework and Asset Management System™

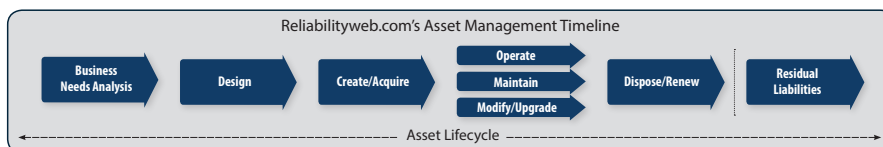

Copyright 2016-2019, Reliabilityweb.com. All rights reserved. No part of this graphic may be reproduced or transmitted in any form or by any means without the prior express written consent of Reliabilityweb.com. Reliabilityweb.com®, Uptime® and A Reliability Framework and Asset Management System™ are trademarks and registered trademarks of Reliabilityweb.com in the U.S.A. and several other countries.

reliabilityweb.com • maintenance.org • reliabilityleadership.com

Uptime® Elements - A Reliability Framework and Asset Management System™ is in use at over 2,800 organizations around the world to engage and empower reliability culture.



The Difference Between an Idea and a Vision

I just finished participating in a collaborative and energetic meeting with a group of special people we call Reliability Partners™. This is a group of Certified Reliability Leaders® who share a deep understanding of the same language and practice of Reliability Leadership®, who place human values as a cornerstone of reliability culture and who spend their work lives advancing reliability and asset management using Uptime® Elements — A Reliability Framework and Asset Management System™.

There were several great ideas developed during the meeting, but the work we were engaged in was far too important to stop at ideas. Ideas are vulnerable and dependent, and do not always create the change we want to see in the world.

If I came to you with an idea to end equipment failures, you would want to know what evidence I could provide to assure the results, what circumstances could affect the outcomes and what basis formed my idea.

Ideas are totally dependent upon the argument they are built on. If any part of the argument falls, the idea falls.

If I came to you with a vision that we could achieve zero accidents, zero downtime and zero waste, you would have a choice. Join us or not. That is the invitation that the Reliability Partners' vision is offering.

You can be for something with NO dependency.

The Reliability Partners' vision depends on nothing. If one is a Reliability Leader who practices life "being" the stand that one takes rather than the way one feels, a vision stands on her word.

My real point is not to leave you with an explanation you need to get an answer to, but to leave you with a possibility, to leave you with an opening that you can stand on nothing FOR something. There is nothing else required but the stand. That kind of leadership takes practice.

Stand on nothing for something. You will be unstoppable.

Stand on nothing for something. You will be unstoppable. Find out how you can stand for zero accidents, zero downtime, zero waste at your organization by sending me a message at zero@reliabilityweb.com.

If you think what you always thought and do what you always do – you will get what you always got. Discover new ideas in the pages *Uptime*, then contribute to the next issue!

Create a new future,

Terrence O'Hanlon, CMRP
About.me/reliability
CEO and Publisher
Reliabilityweb.com®
Uptime® Magazine
<http://reliability.rocks>



IN THE NEWS

RELIABILITY® is a registered trademark of Reliabilityweb.com.



KEYNOTE JUST ANNOUNCED!



Rob Wilson, Innovator, Entrepreneur, Leader

The Innovator's Lifestyle: Harnessing Innovation for Fun & Fortune!

INNOVATORS NEEDED!

Do you want to:

- ✓ Solve Problems Faster
- ✓ Recognize Opportunities
- ✓ Handle Change Easier
- ✓ Boost Your Self-Esteem
- ✓ Gain Greater Comfort with Risk

In this highly entertaining and interactive presentation, Rob Wilson will show you how to generate powerful ideas for your business. Through his captivating stories, he provides real-world content that you can immediately apply to get better results in your business and in your personal life.

SAVE \$200

Register 2/28/19

REGISTER TODAY AND RESERVE YOUR SEAT!

www.reliabilityconference.com



Reliability Leadership Institute Hosts SDMyers' Transformer Management Training

Reliability Leadership Institute® hosted the 3-day workshop, Transformer Management Essentials. Attendees left the event with a foundational understanding of the internal and external elements of the transformer, the essentials of transformer operation and maintenance implementation and related industry standards.

SDMyers is an approved Reliability Partner that supports the Uptime Elements Framework and the 4 Fundamentals of Integrity, Authenticity, Responsibility and Aim. For more information: reliabilityweb.com/directory/details/sdmyers



Reliability Partners Create a Vision



In their first meeting of 2019, Reliabilityweb.com's Reliability Partners gathered at the Reliability Leadership Institute to collaborate on their role to advance reliability and asset management. As discussions circled around words such as *solution, ownership, a common voice*, one clear message was heard: There is a new way to get reliability!

Reliability Partners see their role as more than only solution providers. They are partners who value the Uptime Elements Framework and build on its foundation. The organizations that form the community of Reliability Partners are proud to state their shared vision:

To advance the industry toward ZERO Accidents — ZERO Downtime — ZERO Waste through a holistic reliability framework.

To see a full list of Reliability Partners, [turn to page 2](#). For more information, contact: crm@reliabilityweb.com



2018

RECOGNIZING THE BEST OF THE BEST!

Uptime magazine congratulates the following outstanding programs for their commitment to and execution of high quality Predictive Maintenance and Condition Monitoring Programs.



Uptime Awards Submissions: Open April 2019!
Visit: uptimeawards.com

Best Overall Program

SOUTHERN GARDENS CITRUS PROCESSING



Southern Gardens Citrus (SGC) is a global supplier of premium, not-from-concentrate (NFC) Florida orange juice. The plant was built in 1994 and can process up to 180 million pounds of oranges annually, store 56 million gallons aseptically, and ship and receive over 100,000 tankers annually. SGC's mission is: "Continuously improve and become the low-cost supplier of high-quality citrus products to our customers, while maximizing returns to our shareholders."

SGC's reliability journey started in 1995 to create a continuum with the aim of improving reliability. Management attended maintenance conferences to benchmark and learn about maintenance best practices. From there, a gap analysis was conducted and used to create a business case to support maintenance and reliability. This case was presented to executive management and approved.

A process- and procedure-oriented culture was established when SGC achieved ISO9000 certification. With the help of consultants, the basics of planning, scheduling, and metrics were introduced. Processes were established to build on our gains and improve MRO, work identification & control, reliability engineering, and capital project management. The establishment of programs, such as management of change, condition-based maintenance, preventive maintenance optimization, and root cause analysis, further moved SGC down the path of reliability.

A partnership with operations was created to foster cooperation and the development of operator-driven reliability, introducing operators to the philosophy of reliability. The engineering function has been adjusted to eliminate failure modes as early and cost-effectively as possible, by engineering the investigation/design phase by collaborating with other departments.

With the introduction of ISO55000, a strategic asset management plan was developed and is presided over and reviewed by executive management. The latest objective is the development of SGC's network to create their own Internet of Things.

All of these processes are routinely audited to assure their integrity and to identify any potential opportunities for improvement. SGC believes that reliability should be designed into assets to minimize maintenance needs.

As stated in our mission, continuous improvement is a cornerstone of the culture, and SGC has since adopted the philosophy of:

"Do the best you can until you know better. Then when you know better, do better." - Maya Angelou

SGC firmly believes in continuous improvement. The company-wide engagement demands providing low-cost reliable assets, ensuring the safety of employees, protecting the environment, and meeting the needs of production. The results have been numerous, but include increased uptime, lowered costs and improved relations with operations.



Best Reliability Engineering for Maintenance Program

CENTRAL CONTRA COSTA SANITARY DISTRICT

Central Contra Costa Sanitary District (Central San) is an organization providing wastewater collection and treatment for over 481,600 residents and 3,000 businesses in Contra Costa County, CA. Central San's main facility is a treatment plant in Martinez, CA, processing an average of 32 million gallons per day of municipal wastewater and providing up to 3 million gallons per day of recycled water to several businesses in the community. In 2013, Central San embarked on a formal asset management program to implement best management practices. The goal of this program is to minimize costs, maximize asset value, and manage risk to serve customers at Central San's committed levels of service. As the new asset management program got underway, it became evident that an effective reliability-based strategy would be critical to the program's success. To meet these maintenance needs, a comprehensive maintenance strategy was developed, employing predictive, preventative, and reliability-based approaches. Over the next four years, plant maintenance was overhauled using best practices, including reliability-centered maintenance, condition assessment, root cause analysis, defect elimination, maintenance reporting, oil analysis, equipment vibration analysis, and improved data management. Staff development became a renewed priority to ensure that operators and technicians would be given the knowledge and skills needed to achieve their goals and the goals of the plant to a high standard of quality and reliability. In addition, several measures were taken to improve accessibility of asset informa-

tion for operators and maintenance staff, including implementation of a district-wide computerized maintenance management system (CMMS) and development of a geographical data interface. Because of these initiatives, Central San has made tremendous gains in operational reliability and efficiency, allowing the organization to better achieve its principal aim - its vision, values, and mission: To protect public health and the environment.

HIGHLIGHTS

- Reliability-Centered Maintenance - Program implemented and reliability-based strategic framework developed from 2016 to 2018.
- District-Wide CMMS - Implementation of a new CMMS software for collection system, pump stations, and treatment plant from 2016 to 2017.
- Maintenance Classification - Maintenance work categorized into reactive maintenance, preventative maintenance, condition-based/predictive maintenance, corrective maintenance, non-maintenance, and improvement/optimization.
- Condition-Based and Predictive Maintenance Program Enhancements - Utilizing several new condition and predictive maintenance tools and techniques to complement existing preventative maintenance program.
- Understand the Condition and Cost Associated with Critical Assets - Includes standardized testing, analysis details, and engagement from operations, maintenance and engineering.
- Data and Document Management - Treatment plant geographical data interface developed to allow easy access to project information, O&M manuals, asset management records, and record drawings, to list a few.
- Maintenance Involvement in Capital Projects - Maintenance staff engagement during planning, design, and construction phases of Central San's capital projects.
- Reporting and Monitoring - Easy access to key reports and in-boxes to allow staff insight on maintenance program effectiveness and a path for continuous improvement.
- Recruiting, Developing and Retaining a Highly Trained and Safe Workforce - Several internal and external resources to aid in succession planning and employ learning and development, such as supervisory academy, management academy, mentorship, and technical learning libraries, to list a few.



Best Asset Condition Management Program

LOOP, LLC



LOOP, LLC, is the nation's largest privately-owned crude oil terminal. Since 1981, LOOP has grown to become a fully diversified crude oil trading and exchange hub, the only facility of its kind in the world. Shippers can off-load crude oil from very large crude carriers (VLCCs), load VLCCs, purchase, sell, exchange, store, blend, or deliver crude oil. LOOP handles far more domestically produced crude oil than international varieties. In February 2018, LOOP became the first U.S. facility capable of fully loading a VLCC for crude export.

LOOP has won several Uptime® Awards, including 2014's Best Work Execution Management Program, 2016's Best Green Reliability Program, and most recently, 2018's Best Asset Condition Management Program.

In 2011, LOOP initiated a new vision: "Market Driven and Operationally Excellent." Related strategies and tactical objectives were developed and implemented early on, which are continuously enhanced for future successes in the evolving petroleum market. As the strategic planning process evolved, LOOP identified a specific strategy to provide dependable and secure execution of services, which adds value to their customers and its owners.

In 2015, LOOP handled 875,646,384 barrels of crude (36.8 billion gallons) at its Clovelly Hub in Galliano, LA — 445,309,410 barrels "in" and 430,336,974 barrels "out." Though there were 12 recorded reportable releases that year, the total volume released was only five ounces, less than a cup.

In 2013, LOOP established a 5-year goal to reduce energy consumption per barrel of crude oil transported by 15 percent (when compared to 2012 baseline numbers). This was accomplished in less than two years. By the end of 2015, energy consumption had decreased over 21.5 percent.

In 2015, a green initiative was introduced to reduce the quantity of mislabeled waste drums throughout all operating facilities. A 99.88 percent success rate was achieved for proper labeling and characterizing waste drums in that same year.

After the first Uptime Award in 2014, LOOP made a commitment not to rest on its laurels. Now LOOP is enhancing their condition-based monitoring program for field assets, as well as an enhanced warehousing program.

In 2018, the recommendations set forth in American Petroleum Institute's (API) RP1173 were implemented for a more structured and integrated pipeline safety management system.

The 2018 Uptime Award was based, in part, on LOOP's Risk-Based Asset Management Program and Asset Management Policy, which was signed and backed by its president.

All LOOP employees, owners and strategic contract partners are once again very proud of their stellar team performance and successes. With an embedded pro-active culture, a clear focus on "getting it right" and a passion for "continuous improvement," LOOP continues its journey toward Operational Excellence.

Best Work Execution Management Program

STANFORD HEALTH CARE

IMPROVING PATIENT CARE THROUGH OPERATIONAL EXCELLENCE

Stanford Health Care seeks to heal humanity through science and compassion, one patient at a time, through its commitment to care, educate and discover. Stanford Health Care delivers clinical innovation across its inpatient services, specialty health centers, physician offices, virtual care offerings and health plan programs.

Stanford Health Care is part of Stanford Medicine, a leading academic health system that includes Stanford University School of Medicine, Stanford Health Care, and Stanford Children's Health, with Lucile Packard Children's Hospital. Stanford Medicine is renowned for breakthroughs in treating cancer, heart disease, brain disorders and surgical and medical conditions.

In the summer of 2016, members of the facilities, infrastructure and safety leadership team observed that the organization, in its common commitment to serving patients, had some room for improvement regarding the process used to deep clean and refurbish hospital rooms, specifically in the Intensive Care Unit (ICU).



The effort to deep clean and refurbish a hospital room is multi-disciplinary and involves several departments: Hospital Administration, Facility Management (FM), Environmental Services (EVS), Engineering and Maintenance (E&M), Infection Prevention and Control (IPC), and Environmental, Health and Safety (EH&S). At the same time, the hospital was at nearly 100 percent capacity, limiting the availability of rooms to be down for required work. To complete one suite of ICU rooms, given the initial state of 14 days per room, would have required months to complete.



Using a LEAN technique of "standing in a circle," the team found that when a patient was relocated out of an ICU room, and the room had been identified for cycle cleaning and maintenance, a series of events would occur in the vacated room that were not always sequenced appropriately. The team also observed that durations between steps varied and there were gaps in the hand-offs between teams. For instance, the nurses would contact Environmental Services to request a room clean; the Environmental Services team would dispatch staff, working around scheduled work; the Engineering & Maintenance team would perform a visual inspection of the room, note repairs that were required, schedule and perform the repairs; Environmental, Health & Safety would conduct industrial hygiene sampling and the Facility Management Team would visit the room to refresh the paint, flooring and furniture. Before the room could be turned back over to nursing for the next patient, it would again need to be deep cleaned by the Environmental Services department.

The interdepartmental collaboration and problem-solving effort reduced the cycle time for deep cleaning, maintaining and refreshing ICU rooms down from several days to mere hours. This effort also resulted in significant industrial hygiene costs that had previously been incurred by rework and the lack of a schedule. As an indirect result, coordination among the teams and quality of work have improved. Most importantly, patient care interruptions have been minimized. This sequenced approach is now being implemented across other SHC interdepartmental initiatives and daily operational programs.

Best Leadership Program

YANBU NGL FRACTIONATION PLANT

Yanbu NGL Fractionation Department (YNGLFD) is the main source of gas feedstocks for the power and petrochemical industry for the entire Yanbu area and the western region of Saudi Arabia. YNGLFD's primary feed is in the form of C2+ liquid feedstock. The C2+ feed is separated into ethane, propane, butane, i-C5 and naphtha through the fractionation unit.

YNGLFD Vision: A leading NGL fractionation facility by 2020 and admired for safety and operational excellence.

YNGLFD Mission: To supply quality fractionated NGL products for the Kingdom's economic growth, capitalizing on operational excellence through our committed talents in a safe, reliable, efficient and environmentally responsible manner fulfilling customers' expectations.



The maintenance division at YNGLFP established a new initiative called **Maintenance Excellence Management (MEM)**, which aims to enhance reliability culture and monitoring performance. MEM looks at fulfilling operational excellence requirements through clear, defined processes; progression to enhance maintenance performance; and bringing excellence into main maintenance processes.

MEM was constructed to be in line with the corporate operational excellence track to consistently and systematically achieve and sustain industry-leading performance in terms of reliability, efficiency, cost-effectiveness, and profitability, while striving for the highest levels of performance in health, safety and environmental stewardship.

MEM CATEGORIES & COMPONENTS:

1. **Compliance** - to Saudi Aramco General Instruction (GI) and Corporate Maintenance Services (CMS) requirements
2. **Maintenance Performance** - and KPIs monitoring
3. **HR Focus** - for "Employee Potential & Competency"
4. **Organization Culture** - for "Innovation, Best Practices, Learning and Continuous Improvement"

MEM ACHIEVEMENTS:

The MEM initiative was applied in early 2017 and the **MEM electronic portal** was established to track activities and monitor progress. Applying the MEM initiatives for one year improved maintenance performance by 4.5 percent. It improved the human resources focus score by 40.2 percent. **The overall score was improved by 18.3 percent.** The MEM initiative is currently at its second wave for 2018.

MEM mainly utilized the available resources and manpower within maintenance divisions; however, two main budgeted items were boosted in 2017. These two budgeted items are: conducting maintenance exchange events and certifying more maintenance engineers, with a total estimated cost of \$70,000.

Implementing operational excellence and MEM resulted in a realized savings of more than 12 million dollars during the first quarter of 2017. At the end of 2017, all monitored maintenance indicators reached the targeted zone and overall maintenance performance was increased by 4.5 percent.



Best Asset Management Program

CENTRAL ARIZONA PROJECT



The Central Arizona Project (CAP) is the largest renewable water provider in the State of Arizona, delivering around 1.5 million acre-feet of Colorado River water each year. CAP is a wholesale raw water provider to more than 50 cities and private water companies that collectively serve the needs of about 5 million people (80 percent of the State's population). CAP also provides water for 350,000 acres of irrigated agriculture and eleven Native American tribes. The CAP service area encompasses three Arizona counties covering nearly 24,000 square miles and includes metropolitan Phoenix and Tucson.

CAP's physical infrastructure includes a 336-mile aqueduct from Lake Havasu on the Colorado River to south of Tucson; 14 pumping plants that lift water a total of nearly 3,000 feet; 1 pump-generating plant; 8 inverted siphons; 3 tunnels and a regulatory storage dam and reservoir. The CAP was authorized by the Colorado River Basin Project Act of 1968 and was constructed by the U.S. Bureau of Reclamation at a cost of more than \$4 billion. Construction began in 1973 and was substantially completed in 1993.

The CAP is operated and maintained by the Central Arizona Water Conservation District (CAWCD), a multi-county special purpose district organized under Arizona law. CAWCD is also responsible for repaying to the federal government Arizona's share of CAP construction costs—about \$1.65 billion.



Best Partnership in Reliability

BRISTOL-MYERS SQUIBB & JONES LANG LASALLE



A reliability journey is not something that any one person, or any one organization, should travel alone.

The reliability partnership that exists between Bristol-Myers Squibb (BMS) and Jones Lang LaSalle (JLL) is significant with 700+ team members who provide integrated facility management (IFM) services to BMS at all of its North American locations.

The initial transition encountered several obstacles, but as the two entities became a single force, a true “One-Team” work culture and mind-set was established. This mind-set has been driven with strong executive sponsorship, combined with frontline leadership. The partnership works with synergy that reliability is everyone’s responsibility and can only be achieved through a fully engaged cross-functional workforce.

Both organizations strive to set the pace in their respective industries. This culture is not lost or diminished when working together. Their latest joint venture is bringing wireless sensors into asset condition monitoring/operational excellence programs. They are truly blazing a trail that requires both sides to draw on expertise to find success. JLL brings experience around the use and application of such sensors, while BMS provides vital information around asset criticality and risk identification for design of system logistics.

JLL has been fortunate to work with BMS. JLL has been fully embraced by the BMS Reliability Excellence community, including representation at all meetings, calls and conferences. BMS sees JLL as a key partner that needs to be part of the process when working toward the solution and such a culture breeds a definite closeness between the two organizations.

Both organizations, BMS and JLL, are Reliability Leadership Institute® members that have fully adopted the Uptime® Elements. This holistic approach provides a common language and platform that has enabled both companies to sit at the same table as partners and find solutions for the problems that inherently plague single organizations around asset management. When both sides of the table are speaking the same language, great things happen. One side owns the contract and the other side manages it, but both have vested interest in seeing it executed in the best way possible.

Reliability synergy states that the whole is greater than the sum of the parts of both organizations. JLL assumes responsibility, while BMS does not relinquish ownership. The mutual respect that exists, this “One-Team” mentality, is a marvel to see in action and is why BMS and JLL truly have the Best Partnership in Reliability.

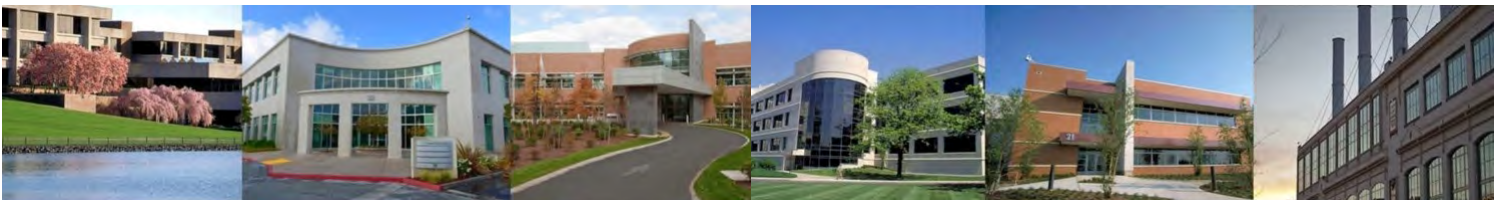

Best Lubrication Program

PGE BEAVER GENERATING PLANT

BEAVER GENERATING PLANT

Beaver Generating Plant, located on the Columbia River, is a 500-megawatt gas turbine combined cycle plant that is owned and operated by Portland General Electric (PGE). Six gas turbine generators and one steam turbine generator produce electricity. When not in operation, the gas turbines are usually maintained in standby, capable of being brought online in 20 minutes. This allows for a peaking type of operation.



LUBRICATION PROGRAM

In 2013, Beaver Generating Plant hired a consultant to perform an analysis of its lubrication program to determine where it could improve its program and asset health maintenance.

- Consolidated its lubricants (greases and oils) by reducing the number of lubricants on-site by consolidating to Mobil products for most of the assets.
- Focus on selecting the right lubricant for the right assets to properly maintain the assets.



- Lubrication schedule was updated, that is used to track lubricant usage against individual components.
- Installed a lubrication work center which allows oil to be filtered upon receipt and while it sits in the warehouse.
- Color-coded system, as well as color-coding the lubrication work center, transfer containers, grease guns and equipment lubrication tags.
- Installed new sampling valves on critical equipment (gas turbines, steam turbines, etc.) to ensure that representative oil samples are collected.
- Oil analysis program for major assets was included in EAM (Maximo) for better tracking and follow-up work.
- Created a fleet-wide oil analysis procedure and equipment-specific oil sampling work instructions.

In addition to these, Beaver Generating Plant recently worked with a consultant to perform calculations on its regreasing task to optimize the amount of grease and the frequency to prevent overgreasing or undergreasing. These changes are currently being implemented.



Digitalization Framework for Uptime® Elements™

Going digital for proactive processes to deliver safe, reliable, compliant, and cost-effective service!

- Create a digital twin of your assets and work in an immersive digital environment
- Always know what and where your assets are and manage change throughout the lifecycle
- Consolidate and analyze IoT and other data sources to make timely decisions
- Improve asset availability while reducing maintenance costs with the right reliability strategy and inspection data management platform



AssetWise
CONNECT Edition

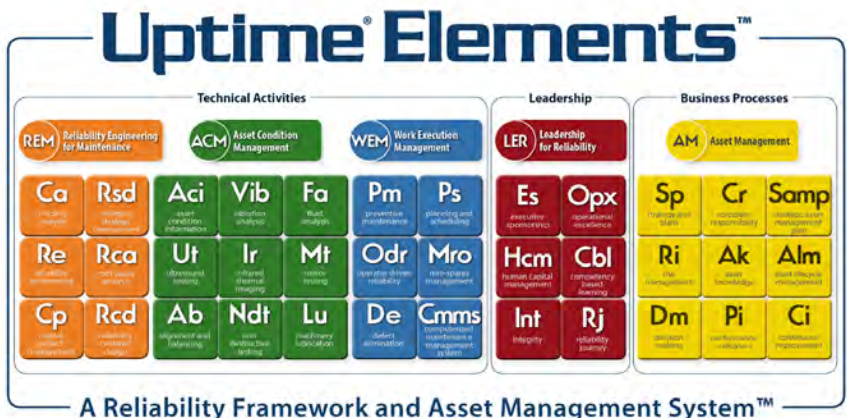

Registered with permission from IntrepidUSA, Inc. ©2018 Reliabilityweb.com. All rights reserved. No part of this graphic may be reproduced or transmitted in any form or by any means without the prior express written consent of IntrepidUSA, Inc. Uptime®, Reliability®, Certified Reliability leader®, Reliabilityweb.com®, A Reliability Framework and Asset Management System™ and Uptime® Elements™ are trademarks and registered trademarks of IntrepidUSA, Inc. in the U.S. and several other countries.

reliabilityweb.com • maintenance.org • reliabilityleadership.com

Download the 2018 Gartner *Market Guide for Asset Performance Management Software* compliments of Bentley!



www.bentley.com/AssetWise



Quartic Platform
AI & IIoT for Smart Industry.

It is time to rethink how we implement **IIOT and AI** for manufacturing.

Put the power of artificial intelligence in the hands of your subject matter experts.

Start your AI lead Predictive Maintenance program at www.quartic.ai

Quartic
AUT1120-UT_PV220
MetaTrainer - Model Creator
Step 2: Define Models

Influencing factors for UT_PV220
Ranked by influence, descending order

Search Variable...	Value
DPS_28431 DRY DR PUMP DRY PRESSURE ACROSS MOTOR AND VACUUM	98
ZSL_28432 DRY VACUUM PUMP SOLVENT CLEANING INLET SEAL VALV CLOSED LIMIT SWITCH	98
P28431_PURGE DRY VACUUM PUMP & MOTOR PURGE COMPLETE	95
P28431_CLN DRY VACUUM PUMP CLEANING	94
P28431_DIAG DRY VACUUM PUMP DIAGNOSIS BY	89
P28432_GP DRY VACUUM PUMP SOLVENT COOLING PUMP FAN SPEED RUNNING	88
ZSL_28431 DRY VACUUM PUMP PROCESS INLET VALVE CLOSED LIMIT SWITCH	86
PT_28431 DRY VACUUM PUMP VACUUM INLET PRESSURE	80
P28431_PLIMIT DRY VACUUM PUMP METRODIA PRESSURE DIFF LIMIT PURGE FLOW DR	79

Model Creation
Click and drag variables to create models

Model A
DPS_28431 DRY DR PUMP DRY PRESSURE ACROSS MOTOR AND VACUUM
ZSL_28432 DRY VACUUM PUMP SOLVENT CLEANING INLET SEAL VALV CLOSED LIMIT SWITCH

Model B
P28431_PURGE DRY VACUUM PUMP & MOTOR PURGE COMPLETE
P28432_GP DRY VACUUM PUMP SOLVENT COOLING PUMP FAN SPEED RUNNING
PT_28431 DRY VACUUM PUMP VACUUM INLET PRESSURE

Step 3: Deploy a Model

Rule: Anomaly score between 90 and 100 for 05:00 minutes

Graphs: Scatter plot and time-series plot showing data points and trends.



Ramesh Gulati and
Terrence O'Hanlon

IMPLEMENTING AN EFFECTIVE

ASSET MANAGEMENT PROCESS

TO IMPROVE RELIABILITY

The 10 Rights of Asset Management process is designed in such a way that ensures organizations will do the right things from the start of the need/concept right through to disposal



Do your physical assets – equipment, machinery and systems – perform as expected or deliver the best value?

Do you know the health of these assets or when they need to be replaced or modified?

Do you have a process established to reduce the total cost of ownership (TCO) and create an operational excellence culture?

This article is designed to guide you in establishing a practical and effective asset management (AM) process that maximizes return on your assets and meets the International Organization for Standardization’s (ISO’s) AM standard compliance requirements.

INTRODUCTION

Organizations operate in a very competitive environment. To survive, they need to stay competitive and must continue to improve processes and get more value, both in the form of return from physical assets and high productivity from human assets (i.e., their people). They need both physical and human assets to be reliable in order to deliver more value to their customers while reducing TCO.

TCO includes all costs incurred during the asset’s entire life: asset acquisition (capital project), asset operation and maintenance, also known as the utilization phase, and asset disposal when the need is over.

The key to making your assets deliver high value is to make your processes robust to ensure:

- Assets are reliable, with minimum failures.
- People, such as operators, maintainers, etc., are engaged to take care of assets. They are:
 - Knowledgeable and skilled to operate and maintain;
 - Continually improving by implementing best practices.
- TCO is kept to a minimum or at an optimum level.

ASSET LIFECYCLE PHASES AND COSTS

Asset life has three major stages, as shown in Figure 1.

1. Acquisition - Designing, building and installing
2. Utilization – Operations and maintenance (O&M)
3. Disposal – Decommissioning and disposing

After a need/concept has been established, the acquisition phase starts. The acquisition phase includes writing specifications, design and procure-

ment of components or the asset, build/fabrication of the asset, and installation/commissioning of the asset for operation.

The asset might be procured already designed/built as an “off-the-shelf” item or designed and built per special specifications depending on the need.

Utilization is the key phase where the asset is operated and maintained for many years depending upon need, which may be 10, 20, 50, 80 years or more. This is the phase where you get the value from the asset.

Disposal, the asset’s last phase, is where it is decommissioned. The asset’s need is over and is either put in the warehouse for later use or disposed of safely.

Based on experience and several subject matter experts (SMEs), the estimated average cost for these phases as a percent of the TCO are:

- **Acquisition Phase** – 22%, with a range of 15% to 30% based on off-the-shelf or unique design;
- **Utilization Phase (i.e., Value Delivery)** – 73% O&M, with a range of 60% to 80% due to asset complexity;
- **Disposal** – 5%, with a range of 3% to 10% due to asset complexity and environmental requirements.

It should be noted that 70% or more of the cost is incurred in the utilization phase. However, this cost is determined or depends on how the asset was designed, built and installed. Some cost-cutting measures during the acquisition phase can force designers and builders to use low cost, unreliable components, causing higher failures and increasing the O&M costs. Cost-cutting actions during installation and commissioning, such as not checking component alignments, not providing appropriate training to O&M technicians, or not having O&M manuals, drawings, etc., can cause higher failures or increase repair time. It has been observed that spending 15% to 25% more during the acquisition phase can reduce O&M costs by 20% to 40%, thus lowering TCO.

To ensure organizations do the right things during the entire life of the asset, they need to establish an asset management process that utilizes the “10 Rights of Asset Management.” This process involves a series of actions or steps taken to achieve lower failure rates by eliminating defects at the source and reducing the total cost of ownership.

ASSET MANAGEMENT PROCESS

The 10 Rights of Asset Management process is designed in such a way that ensures organizations will do the right things from the start of the need/concept right through to disposal. It requires that all people/stakeholders follow the process, which includes work instructions, procedures, policies, etc. The process should be repeatable with less variance and auditable.

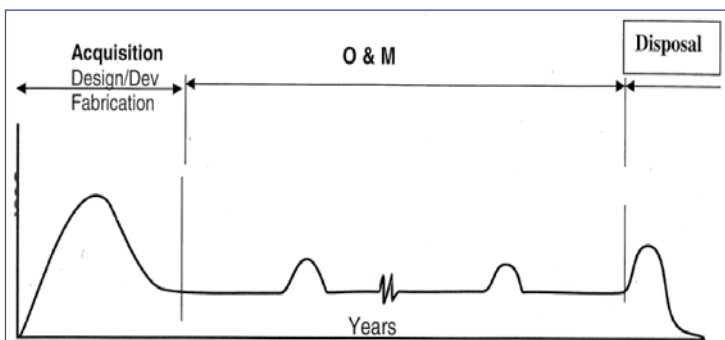

Figure 1: An asset’s lifecycle



THE 10 RIGHT STEPS TO ESTABLISH THE PROCESS ARE:

- 1. Specify It Right**
Ensure that the right people are involved in writing requirements and specifications for the asset needed.
- 2. Design It Right**
Ensure that you are designing for reliability, availability, maintainability, safety and sustainability (RAMS²), including operability and to reduce TCO.
- 3. Source/Procure It Right**
Ensure you are procuring the components or asset to deliver the best value, not the lowest cost.
- 4. Build/Fabricate It Right**
Ensure that the asset is being built by skilled people using quality components.
- 5. Install/Commission It Right**
Ensure that the asset is installed with precision and quality workmanship to eliminate any infant mortality failures.
- 6. Operate It Right**
Ensure that operators are able to operate the asset safely and have been trained appropriately to take care of the asset as if they own it.
- 7. Maintain It Right**
Ensure that the asset is maintained with the right maintenance strategy/plan.
- 8. Improve It Right**
Ensure that you are applying the right tools and practices to improve asset performance on a continuing basis.
- 9. Dispose of It Right**
When the need is over, decommission/dispose of the asset in a clean and safe manner.
- 10. Manage It Right**
In this step, you need to set up a process to ensure you perform all the previous nine steps properly all the time. Also, you need to ensure that you are hiring the right people to perform all the tasks mentioned and continue to develop their skills.

Setting up the 10 Rights of Asset Management process may require the organization to be in compliance with ISO9001 (Quality Management), ISO14001 (Environmental Management), ISO55001 (Asset Management), etc. In fact, if you set up your process properly to do the 10 Rights, your process should meet all the ISO standards requirements.

CONCLUSION

To survive in today's competitive environment, organizations must continue to improve processes. By doing so, they will get more value and return from physical assets and high productivity from human assets. Both physical and human assets need to be reliable in order to deliver more value to customers while reducing total cost of ownership.

In order to get more value from their assets, organizations must make processes robust and reliable so they can deliver quality products or services that make their customers happy. Implementing the 10 Rights of Asset Management process is one of the effective methods to achieve this objective.

REFERENCES

1. Gulati, Ramesh and O'Hanlon, Terrence. *10 Rights of Asset Management*. Fort Myers: Reliabilityweb.com, 2017.
2. Gulati, Ramesh. *Maintenance & Reliability Best Practices*. South Norwalk: Industrial Press, 2012.
3. International Organization for Standardization. <https://www.iso.org/home.html>
4. Gulati, Ramesh. *Uptime® Elements Dictionary for Reliability Leaders & Asset Managers*. Fort Myers: Reliabilityweb.com, 2017.



ORDER YOUR COPY TODAY!

10 Rights of Asset Management

Achieve Reliability, Asset Performance and Operational Excellence

reliabilityweb.com/bookstore



Ramesh Gulati is an Asset Management & Reliability Leader with Jacobs. Ramesh is a world-renowned leader in the maintenance, reliability, and asset management field, where he is known as a "Reliability Sherpa." He is the coauthor of the book, *10 Rights of Asset Management: Achieve Reliability, Asset Performance and Operational Excellence*.



Terrence O'Hanlon, CMRP, is the CEO and Publisher of Reliabilityweb.com and Uptime Magazine. Terrence is an asset management leader, specializing in reliability and operational excellence. He is a popular keynote presenter and is the coauthor of the book, *10 Rights of Asset Management: Achieve Reliability, Asset Performance and Operational Excellence*. www.reliabilityweb.com



10 STEPS

TO PRECISION MAINTENANCE RELIABILITY SUCCESS



Awareness of Today's Business Issues, Trends and Critical Skills Shortage

While many factors contribute to lost opportunities for today's manufacturers, equipment failures and breakdowns continue to be near the top of the list. Real data from over 200 facilities show that maintenance induced defects overwhelmingly contribute to stalled improvement efforts to gain back control. Much of the data indicates roughly 25% are common assembly errors, 25% are from imbalance and poor balance specs, 25% are common lubrication mistakes and 25% are from poor alignment, inadequate alignment specs and a general lack of leadership expectations and follow-up. The plain truth is most craftspeople entrusted to maintain millions of dollars of production and support equipment have never been taught the necessary precision skills and how to apply them correctly to, as the saying goes, "do

it once and do it right." To further complicate the issue, most managers and supervisors don't understand nor set and enforce the necessary standards.

As stated in a 2018 ManpowerGroup research report, 45 percent of employers say they can't find the skilled workers they need. Exacerbating this even more is that manufacturers are expected to lose another two to three million experienced workers due to the looming retirement within the baby boomer generation. Because of these vacancies, industry analysts predict that over the next decade, more than two million manufacturing jobs will go unfilled across the U.S. Currently, the National Association of Manufacturers reports there are 391,000 open jobs in American manufacturing today.

The specific roles needed to fill this talent shortage are most acutely in skilled production and maintenance, such as machinists, mechanical repair personnel, operators, and electrical and instrument technicians, which together amounts to more than 50 percent of the manufacturing workforce. Additionally, 67 percent of respondents reported a moderate to severe shortage of available, qualified workers and 56 percent anticipate the shortage to grow even worse.

The “2018 Deloitte and The Manufacturing Institute Skills Gap and Future of Work Study” goes into extensive detail about this same problem and provides additional insight.

The opportunities to set a higher standard of improvement and sustained success are truly astounding. To succeed, the development and application of precision skills should be based on the fundamental expectation that plant equipment must be maintained correctly in order to become a reliable plant. The results are real: improved equipment performance and extended life – it drives everything good financially and is strategic to manufacturing success.

Having gained a better understanding of the precision skills gap, the next steps show how organizations can effectively address it.



The Birth of Precision Maintenance

As you will read, the technical definition and goals of precision maintenance are pretty straightforward.

The first real evidence of precision maintenance skills and techniques were pioneered at NASA by Dr. Wernher von Braun and his team of genuine rocket scientists in the 1960s. Through rigorous hours of testing, they discovered that for every “20% vibration is decreased, the life of the bearing is DOUBLED.” Further reductions produce exponential increases in bearing life and all other expensive components that usually get damaged during bearing failure. Additionally, unscheduled downtime is eliminated and there is a drastic reduction in maintenance costs.

Another early vibration pioneer, Ralph Buscarello (respectfully known as the “Vibe-Father” to those who knew him and studied under him), understood and passionately preached well into his 80s that common assembly errors, mistakes and omissions of the essential field installation and rebuild details, along with simple equipment specification issues at purchase, are significant sources of destructive vibration that eventually fatigues the bearing metallurgy casing, causing the bearing to failure. Ralph coined the phrase, *precision maintenance*, back in the 1960s and spent the rest of his life trying to spread the word.

A rigorous implementation of precision maintenance creates the highest standard of reliability. Precision maintenance is comprised of tested, critical, must-do steps of implementation, the results achieved and continuous improvement that must include constant follow-up to ensure sustainable success.

Even plants recognized as the most reliable in their industry will find they have barely scratched the surface of precision maintenance. Typically, what is missing is the key component of convincing managers and supervisors to become real leaders and LEAD CHANGE!

To achieve the desired results require setting new expectations, measuring, constant follow-up and never allowing yourself to digress to the previous poor habits brought on mostly by human nature. In other words, you have to create and put processes in place that ensure rigid specifications are followed by every mechanic, project manager and supervisor.



Precision Maintenance Skills Assessment

The skills gap is the difference between the skills required to perform a specified job and the actual skills that employees possess. Conducting a skills assessment provides an objective measurement of a craft, for example, a mechanic’s knowledge and understanding of precision maintenance skills,

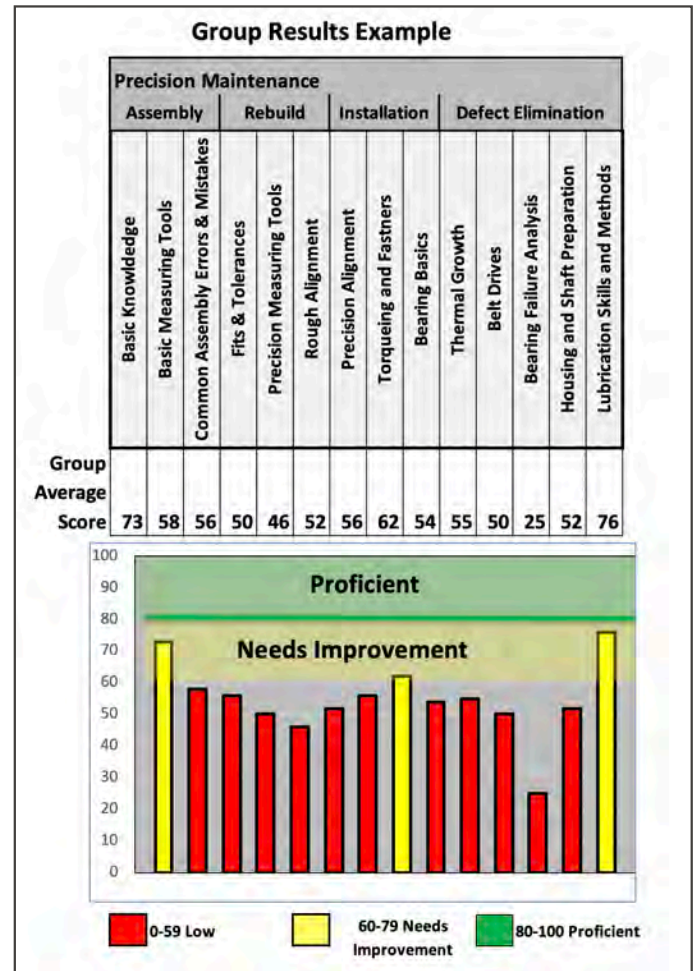

Figure 1: Skills assessment

how they are applied and the strategic value they can mean to the company’s improvement initiatives.

A skills assessment provides a scoring system that measures results: low, needs improvement and proficient. This scoring system is applicable for each topic and covers a myriad of assembly errors, mistakes, omissions, precision assembly, rebuild, installation, bearing fits and tolerances, precision alignment, and mechanic or engineer induced unbalance. A review of the results for over 1,000 assessments of existing personnel and new hires shows that 95 percent score at the low level, compared to five percent who score at the needs improvement or proficient levels.

With these results, a defensible and sensible precision skills training plan can be formulated with the objective of transforming the workforce into a highly skilled craft team that is fully trained and qualified to place equipment into a *precise state* and effectively *maintain* a fleet of reliable machines that deliver value to the company’s strategic objectives.



Senior Management Sponsorship and Leadership

Achieving precision maintenance implementation, success and sustainability requires the full sponsorship and advocacy of senior leadership, as well as supervisory and manager roles. There should be a clear focus on setting written expectations for mechanics, engineers, planners and all contributing roles, including operating in accordance to improvement objectives.

Empowering People and Teams

Empowering people and teams. Managers empower people and teams so they are able to take the initiative without any hindrance or bureaucratic obstacles, make the best decisions to solve problems, and improve service and performance. Empowerment builds confidence, creates satisfaction, encourages innovation, and is a great morale booster.

Create a culture of excellence and continuous improvement

Managers should build an environment where everyone works together to develop the best solutions to problems, without any consequences of an adverse outcome. They are willing to take the appropriate risk without any fear and ensure continuous improvement becomes the norm.

*Reference: 10 Rights of Asset Management
Ramesh Gulati and Terrence O'Hanlon*

- There must be a clear understanding of the strategic connection between reactive, unscheduled downtime due to improper work habits and, conversely, how applied precision skills are essential to the performance improvement of equipment, reduced manufacturing and energy costs, and increased production.
- All contributing roles must see leadership's commitment to follow through and how they align with the way people think, behave and work.
- By leadership leading and engaging, the workforce will recognize their role in building a reliability culture that runs through every fiber of the manufacturing site.



Direction: Processes, Communication and Standards

Maintenance management and all significant roles must understand how they each contribute to moving this improvement work forward, including: job plans, field documentation, planning and scheduling precision work, and setting the expectation that from here on in, as pointed out in Winston Ledet's book, the battle cry is, "Don't Just Fix it, Improve it!"

Managers and supervisors ask their people all the time to change and improve what they are doing, but they don't do a particularly good job of describing in detail what that looks like for the mechanic, the lubricator, the planner, the vibration analyst, the supervisor and other staff functions.

So, you need to work with each functional group, writing work guidelines and expectations for each contributing role that clearly define what they need to do differently during and after each training class.

Just a few examples of procedures and expectations for craft mechanics are:

- When performing alignment, you will find and correct gross soft foot first, then check and correct any induced angled soft foot created by resulting alignment shim changes.
- Carefully follow written step-by-step pipe strain check procedures on all new installations. NO PIPE STRAIN will be acceptable before signing off with the contractor.
- Machine key orientation will be precisely followed on all precision maintenance jobs. Keys will normally, unless specified otherwise, be placed (rotated) 180 degrees apart on all coupled equipment.

The excitement of discovery can be a source of pride when work is performed precisely and will not take more time when planned and scheduled in

advance. For instance, it doesn't require four to eight hours to do a precision alignment if the mechanic is prepared and follows expectations to lift and clean the base and feet, and investigate to find and correct gross soft foot before mounting the laser. Mistakes are commonly made when this step is skipped because it is not set in writing: "Thou Shalt Better Not Skip This Step."

It has been proven time and time again that having detailed writings for procedures and expectations, supervisors' compliance to expectations and reporting real results to management are the essential requirements to achieving precision alignment in a shorter period of time.

Equally important to achieving success, without a doubt, is creating, then requiring, each job to have a precision maintenance field worksheet to follow. This worksheet features a step-by-step format, with actions and findings fully documented by the craft mechanics, reviewed and signed by the frontline supervisor and turned in at the end of the task to planners and maintenance engineers for any required follow-up. Post-work can provide craft mechanics with a direct voice in pointing out deficiencies that could not be addressed on that job, that day, and require follow-up improvement work or parts on-site. Some examples might be: "SW foot bolt-bound 1/4 inch, cannot get precision alignment today;" or "Outboard bearing housing worn out, egg shaped by .008 inches, part not in stores, bearing will fail again soon."

Likewise, supervisors and planners must follow written expectations as to whom will collect, read, follow-up, order new parts, reschedule and report conclusions back to the mechanic who initially wrote the additional work to be performed. Everyone needs to be fully aware of their and others' roles and responsibilities, especially the role assigned to follow through with review of each precision maintenance job worksheet. Additionally, all worksheets should be reviewed weekly in the planning meeting to determine the best course of action regarding the following week's schedule and upcoming shutdown.

Communication and Standards

Before starting implementation and training the workforce, establish a detailed communication plan based on expanding awareness of what precision maintenance is and the existing gaps. It's just as imperative to establish new installation standards for contractors and new rebuild standards for outside repair shops. Facilitate the writing of these standards with input from your best craftspeople, supervisors, planners and engineers. In like manner, identify the metrics to show progress and results. If the facility does on-site rebuild of spares, just as important is establishing a "clean room" for assembly of spare rotating and hydraulic elements, as well as mechanical seals.

Along the journey, it is advisable to keep the workforce informed of equipment improvement progress, such as decreasing vibration and energy consumption. Make it a point to communicate these results back to the individual craft mechanics responsible for improving equipment performance and leaving equipment in a precise state. Significant findings and equipment modifications must be communicated and a commitment secured for the workforce to employ any new tool or modifications on a more global scale across the entire plant or similar equipment types.

Precision Standards

While many precision standards are documented, and many continue to be discovered, here are a few examples that serve as a guide to add, modify and build your own standards in accordance to site objectives:

- Before a bearing housing and/or shaft is considered for reuse in a bearing installation, detailed measurements for proper fit and tolerance, as compared to original equipment manufacturer (OEM) specifications, shall be required and well-documented.

- All new bearings will be measured for final dimensional quality compliance before installation.
- All new pumps and fans shall be ordered with an impeller balance quality of G1.0 at **no additional cost!**
- Key stock in stores and area shops all shall be ordered to attain readily available plus tolerance, and all keys individually fit to keyways with a push/pull interference fit (0.0003" to 0.0005").



Training Implementation

Following the skills development training plan (derived from the precision maintenance skills assessment) and the establishment of processes, participants should learn the principles of defect elimination and how they are achieved by the application of precision skills and methods.

Participants perform numerous hands-on, step-by-step exercises on simulators that replicate real-world, operating equipment, specifically engineered to enable instructors to impart a myriad of assembly errors and common mistakes. Participants are then systematically taught to identify and eliminate each one. In this way, participants learn each precision skill, eliminate defects, demonstrate ability and achieve precision maintenance qualification.



Figure 2: Vibration readings taken "as found," before work and "as left," once work is completed

People Development: Education and Training

People get things done. Managers may have detailed plans and amazing processes, but if the right people with the right skills aren't in place, these plans and processes can't be carried out effectively. Developing the workforce at every level and empowering them to do their best is the key to success.

Training also sends the message that employees are valued and that management is interested in their development and betterment.

*Reference: 10 Rights of Asset Management
Ramesh Gulati and Terrence O'Hanlon*



Application of Skills

With their new skills, knowledge, tools and improvement work orders, craft mechanics can immediately begin to transform poor, high risk of failure machines into improved, reliable machines that are operating as intended, with increased resistance to failure.

Once the necessary training is completed, supervisors assign each craft mechanic a precision maintenance job work order to be completed in his or

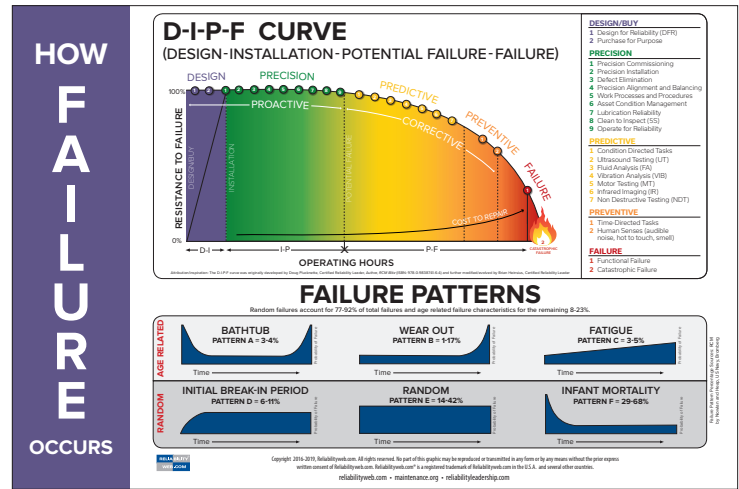

Figure 3: D-I-P-F curve illustrates that the application of precision skills enables equipment to operate on-top-of-the-curve. Why? Increased profit retention

her area. The mechanic should be given time in the schedule to place each machine in a precise state and report findings back to the supervisor. In accordance with the communication plan, maintenance reliability engineers, vibration analysts, planners and anyone who is fostering support and advocacy for a higher standard of work, are all made aware of the results.

This is where craft mechanics can deliver real value. Precision assembly, installation and rebuild occurs throughout the operating lifecycle of site equipment, not just at commissioning. By raising the quality standard of work, defects are eliminated by not imparting them in the first place, as illustrated in the D-I-P-F curve in Figure 3. Together, all the precision elements serve as the essential enablers for equipment to be skillfully placed in a precise state, whereby they operate on top of the curve for a consistently longer time. This is the aha moment for craft mechanics, when they begin to understand the real meaning of, "Don't Just Fix it, Improve it!" or **do it once and do it right.**



Measuring Results - Key Performance Indicators

The most effective way to measure results is with key performance indicators (KPIs). Some examples (Figure 4) of KPIs that can be established are:

- Number of improvement work orders completed monthly;
- Reduced energy consumption;
- Reduced overall vibration levels;
- Mean time between failures (MTBF) and how it powers achievement of all good things financially;
- Increased incremental production;
- Reduced manufacturing costs.



Progress Review and Mentorship

Conducting a progress review three to six months from implementation can provide maintenance management with valuable continuous improvement recommendations because it shows where success is being achieved and validates that skills are being applied. A progress review also demonstrates that frontline supervisors are actively involved in communicating precision maintenance expectations with planners and craft mechanics.

This approach serves to inform and assist the site in recognizing the importance of establishing and continuously improving those processes that will guide the leadership team in achieving significant improvements that will power the site's production, deliver measurable results and create a sustainable reliability culture.

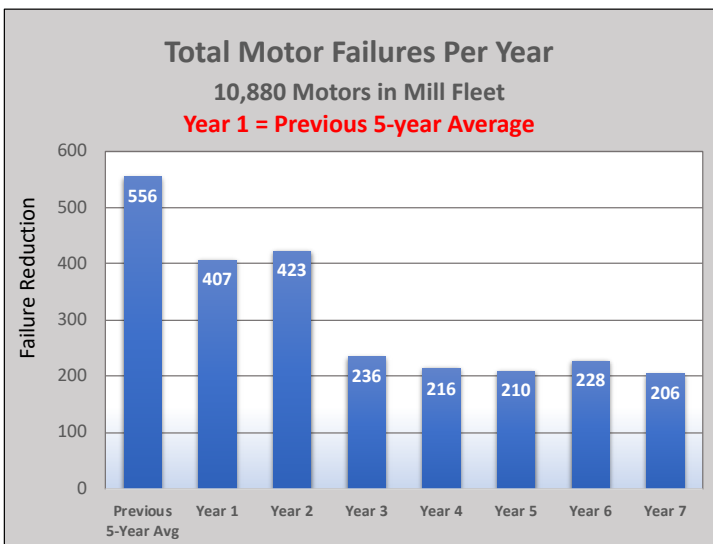
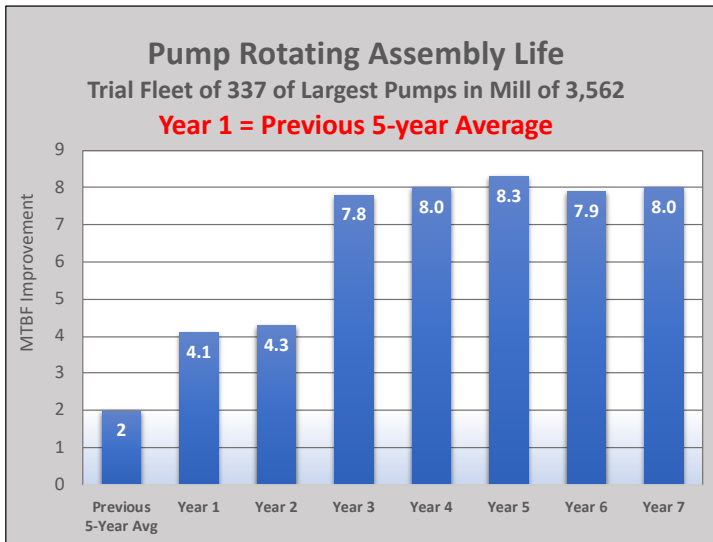

Figure 4: Real results achieved and sustained by one of the largest paper mills in the world

- 4a: Pump “mean time between failure” (MTBF) greatly increased
- 4b: Motor failures significantly reduced

Frontline supervisors should establish a process for reviewing the documentation of each precision maintenance job, recognizing the quality of work and, if additional mentoring is needed, reinforcing the continuous improvement of each craftsman.

The objective of field mentoring is to assist the site team with the necessary recommendations to move improvement work forward efficiently and effectively.

Examples are:

- Formulating precision job plans;
- Reviewing the asset list and criticality rankings;
- Accurate bill of materials (BOMs), including key safety and technical procedures;
- Work order history to look for opportunities and areas of improvement;
- Current workflow process;
- Facilitate the building of a “bad actor” list using criticality rankings, work order history, latest vibration readings, cost history and site knowledge;
- Planning and scheduling precision work.



Achieving Sustainability

All the previous steps are proven best practices and essential in achieving a standardized reliability precision maintenance process – the highest level of success with a sharp focus on continuous improvement. For best practices learned, the maintenance manager and his or her staff should make note and recognize when craft mechanics discover something new that can be added to work procedures. Conversely, if you observe something being done incorrectly or old habits reemerging, take immediate and decisive action to correct it and reset the expectation.

As the culture begins to change in the precise direction you seek, the written procedures and instructions will become a solid foundation and mechanics will expect to have good written procedures, specifications and job details. Insist that operations and production superintendents attend training with the maintenance crews. This way, they learn how they can support the effort and why maintenance is doing things differently. Make sure their shift leaders understand their responsibility to sign off every time they authorize or insist that something be “just put back together, I got to make my shift production.” After follow-up questions by the plant and/or mill manager, such actions should be put to rest.

Each individual site must recognize the barriers and constraints that will emerge to challenge the established processes and commitments made. Each site must be dedicated to stay on the journey and not revert back to the past status quo of reactive, low quality work.

Those that have remained diligent to precision maintenance work standards are no longer deploying their craft mechanic teams to relentless, failure-based work. Now, their focus is on improvement-based work. It’s a paradigm shift in strategy, principles and tactics, and these organizations are winning big.

What does your organization need to do to be part of the change to Precision Maintenance reliability?

Resources

1. ManpowerGroup. “Solving the Talent Shortage: Build, Buy, Borrow, Bridge.” *2018 Talent Shortage Survey*. [https://go.manpowergroup.com/hubfs/TalentShortage%202018%20\(Global\)%20Assets/PDFs/MG_TalentShortage2018_Io%206_25_18_FINAL.pdf](https://go.manpowergroup.com/hubfs/TalentShortage%202018%20(Global)%20Assets/PDFs/MG_TalentShortage2018_Io%206_25_18_FINAL.pdf)
2. Deloitte and The Manufacturing Institute. “2018 Deloitte and The Manufacturing Institute Skills Gap and Future of Work Study.” https://www2.deloitte.com/content/dam/insights/us/articles/4736_2018-Deloitte-skills-gap-FoW-manufacturing/DI_2018-Deloitte-MFI-skills-gap-FoW-study.pdf
3. Reliabilityweb.com. *Uptime® Elements— A Reliability Framework and Asset Management System™*. <https://reliabilityweb.com/uptime-elements-academy-lms>



Phil Hendrix is CoFounder and Owner of Hendrix Precision. Phil began his career with a job welding in a fab shop at the age of 14. Since that time, he has worked in a variety of roles in the industry and over the last 15 years, has provided successful consulting services to over 200 companies and plants. www.hendrixprecisionmaintenance.com



Bill Yantz is Vice President at Hendrix Precision. Bill has over 38 years of experience, during which he has held leadership capacities and served as a trusted business advisor formulating asset improvement solutions and guiding corporations in improving equipment life, reducing downtime, and lowering overall manufacturing costs. www.hendrixprecisionmaintenance.com

**7 Uptime Awards
Received by our Clients
YOU COULD BE NEXT!**



**Reliability-Centered Maintenance
Software • Consulting • Training**



**JMS
SOFTWARE**



Uptime® Elements ©2016-2019, Reliabilityweb.com. All rights reserved.

www.jmssoft.com

LEADERSHIP

IS VITAL TO SUCCESS

Roger D. Lee

Leadership is vital to the success of all companies. It is a journey that requires reference points to ensure leaders remain on course and continue to grow. Almost all companies need more deliberate and focused leadership development. They need leaders who inspire people to follow. This is especially true when implementing successful work processes. This article describes the needed steps, as well as the roles and responsibilities required, for implementing successful work processes and a leadership structure.

Establishing a leadership structure starts with organizations setting expectations for their leaders. It is important for all leaders in an organization to understand and share a consistent message to all its employees from the top down. Employees need to see principle-based behaviors from their leaders. Leaders clarify key performance expectations and link them to training to ensure an understanding for exceeding compliance.

“
In any organization, the people are the secret ingredient to its success
”

Leaders must be ready to leverage moments of high influence that naturally occur every day to communicate their vision. This also allows them to connect their decisions to the organization's established core values. Leaders must practice zero tolerance for deviations from these core values.

In any organization, the people are the secret ingredient to its success. Leaders must have people making the right choices all the time. What they do or do not do determines the end of the game and the success or failure as

leaders. With this fact in mind, leaders must be passionate about personal and process safety and positive behaviors to achieve the shared vision.

The Leader's Roles and Responsibilities

Leaders must lead with a vision of the future. It is impossible to get your people where you want them to go if you do not know the final destination. You would never take your family on a vacation by loading up the car and then asking them where they want to go. Employees want to feel that their leader has clarity, confidence and optimism about the future and has a plan with enough details to show them the steps they will need to take.

As the leader, it is your job to maintain the focus and direction of your people while minimizing distractions. Lead with a can-do winning spirit to drive continual improvement while reinforcing step changes to sustain success. The leader must define consequences for their employees' actions, with explanations for each to ensure positive participation.

It is an honor and privilege to be selected as a leader. As a leader, you are to focus on others and care about them, as well as their ideas. But, you cannot do everything alone. Pick your team members wisely to have optimum success. Your leadership elements are critical to the creation and implementation of successful work processes.

Steps to Achieving Successful Work Processes

When it comes to work processes, organizations must allow time to do each job safely. They must keep plans and procedures up-to-date and accurate by incorporating real-time feedback from the field that proactively identify and eliminate hazards.

Leaders are responsible for personally setting the tone for excellence, with operations and maintenance as true partners. Link all the systems and procedures, work processes, administrative techniques and tools used to



conduct all your business. Create and coach a daily work process discipline that expects ownership by the operator, mechanic and all parties involved in the work processes. Guard against complacency and accepting the status quo as good enough. Lead by example, such as wearing proper personal protective equipment (PPE) to show your employees that everyone should watch out for one another. All components must function like a winning race team to gain the victory everyone desires.

Leaders should be available and accessible as much as possible to provide guidance. They should communicate at a level that their people understand. When things get really tough, do not get discouraged, rather try to remember that this too shall pass.

“ **Leaders must lead with a vision of the future** ”

Lead by storytelling to give personal examples of similar times when you were successful. Remember, providing positive reinforcement is the only way to improve performance. Negative reinforcement will only ensure compliance.

Build confidence in your employees by recognizing and rewarding good behaviors and results. A simple and sincere “Thank you” will go a long way. Address issues early to make needed corrections and show appreciation for improvements.

Coaching is your job wherever you are. You have to coach out time for coaching daily. Invest time to know your people. Coach for performance and lead with questions, not answers, to ensure

your people understand. Coach your employees to think about the right thing to do (i.e., think, act, verify). Remove obstacles to their success. Ask for their input on what you can do or stop doing to help you be a more effective leader. Remember, you always get more of what you measure and reward. Intervene where appropriate in a timely manner by understanding what happened and what people were thinking. Redefine failure as something that happens to you, not something you are. All people have valuable contributions to make. Your employees will do what they are coached to do.

It is your job to support downward and challenge upward. You serve as your employees’ filter for all the things rolling downhill. Be a good buffer to keep them focused on the items within their control. Communicate a lot, up and down the organization. Employees need to sense optimism and confidence from you that there will be a better future, as well as clarity around actions to achieve it.

Measuring Leadership Performance

Your leadership performance is measured by what your followers do. It is insane to use the same coaching over and over and expect them to do something different. Help them solve problems and grow to ensure overall success and satisfaction. Seek to understand before being understood. Your success as a leader depends on your people. Commit to developing all your team members to their full potential through job assignments, coaching and training. Consider strengths and interests when making assignments. Your goal is to develop yourself and others in a continual learning environment. Seek and value feedback about yourself, team members and team performance. Instead of being a leader who *gets work done through people* (i.e., the end result is task completion), make it your job to *get people*

done through work (i.e., the task helps achieve the end result of changing and improving people).

Establish clear expectations and then role model the desired behaviors to achieve them. Clear communication is key. Always verify understanding by the person being addressed. This question interaction will enhance your relationship, too.

Remember to inspect what you expect. This adds accountability for their performance. As you lead your people, be accountable for personal and organizational results, being careful to show them how they have made a positive impact on each. Your employees are always watching your actions, so everything you do (or don’t do) matters. Your example is the only thing that matters in influencing your people. Do what you say you are going to do.

Scoring Yourself as a Leader

How do you know if you are doing a good job? Positive feedback from your employees answering the following questions is a great indicator:

Do I know what is expected of me?

Do I have the materials, equipment and knowledge to do my job right?

Do I have the opportunity to do my best every day?

Have I received reinforcement for good work in the last week?

Does my supervisor or someone at work seem to care about me as a person?

Is there someone at work who encourages my development?

It is healthy to routinely seek these answers from your circle of influence. To score yourself as a supervisor, answer these questions from your perspective and those who report to you.

Your employees will achieve self-motivation when they feel and believe that: I am heard; my ideas contribute to the business; I belong here; I receive recognition; I am competent at my job; I am learning; I have control over how safely I choose to work; I actively care about the safety of others; and I accept negative feedback and take actions to improve based on that feedback.

Being Part of the Leadership Structure

All leaders are part of many teams up and down the organization. To be successful, your role as a leader is most critical as a participant of the site leadership team (SLT). Each member of the SLT must be a champion for the organization's core values, established processes and the safety and leadership of its people.

SLT members must focus on results, as well as leader/people capability development. They must be mindful of talent flow to build for the future (reward with growth opportunities). They have to take care of today and tomorrow.

SLT members also must:

- Be a champion for change with proper prioritization to keep the organization's limited resources focused.

“Do what you say you are going to do”

- Encourage an “act like an owner” perspective and behavior from all employees.
- Understand and leverage employees' strengths and interests to help them grow and align their passion with career paths.
- Clarify for employees how they fit into the strategies for the vision of the company and organization.
- Confront the facts in a constructive and respectful discussion to learn from mistakes and grow for the future.
- Replace bad behaviors with positive ones to make the bad ones go away.
- Establish trust through a relationship-focused environment.
- Appreciate and leverage the diversity within the work group to ensure overall success.

Conclusion

In every situation, what leaders don't know, they ask. They make the right choices and always lead by example.

Good leaders make sure they follow safety rules, take time to do each job safely, report all

job-related injuries, identify and eliminate hazards and watch out for each other. They are committed to keeping their people safe so they can go home each night and return the next day.

Good leaders work themselves out of a job by developing their replacement. Leaders know that the best way to the next job they desire is to leave behind an organization that continues to grow after they are gone. They make sure that learning, innovation and continual improvement are key attributes for an organization's culture.



Roger D. Lee is the President and Founder of RDL Solutions, LLC. Roger retired from Eastman Chemical Company as the Global Manufacturing Optimization Manager after 35 years of service and has 42 years of experience in the chemical and refining industry with clients from across the world.

NO EXCUSES
FOR OVER/UNDER LUBRICATION

Poor lubrication practices account for upwards of 40% of bearing failures. There's no excuse for over or under-greasing your bearings! Improve reliability and save money with our ultrasound tools by making lubrication a condition-based task instead of a time-based task. Our equipment and support are the industry benchmark. **Keep it running.™**

305.591.8935 | ludeca.com

SDT270
The Ultrasound Solution

LUDECA



©2016-2019, Reliabilityweb.com

HANDS-ON PRECISION MAINTENANCE TRAINING

On-Site | Open School Courses | Distance Learning

WHY? We show you how to Double, Triple Rotating Equipment life through the application of Precision Maintenance - Defect Elimination skills."

"Do it Once – Do it Right"



Open School Schedule | 2019:

Precision Maintenance Skills 1: Machinery Assembly, Rebuild, and Installation

Feb 11-15 Houston, TX | Feb 25-Mar 1 Plaquemine, LA | April 4-8 Lake Charles, LA
May 13-17 Plaquemine, LA | June 10-14 Chicago, IL | July 15-19 Decatur, AL
August 12-16 Lake Charles, LA | Oct 21-25 Greenville, SC

Precision Maintenance Skills 2: Precision Bearing Installation

Jan 29-Feb 2 Decatur, AL | Sep 17-20 Houston, TX | Sep 24-27 Plaquemine, LA

Precision Maintenance Boot Camp for Engineers, Leadership, etc.

May 6-10 Lake Charles, LA

To Be Announced: Los Angeles, New Jersey, Salt Lake City



Contact Information: 615-927-0164 | byantz@hendrixpm.com | hendrixprecisionmaintenance.com

Emerging Industrial Internet Technology Can Reduce Costs and **DANGERS** in

STEAM

SYSTEMS

Brian Alessi

“
With the emergence
of industrial Internet
technology, steam traps
make ideal candidates
for automated sensing
technology
”

Steam systems are vital to the smooth operation of so many manufacturing plants and other facilities. Numerous components are at work to ensure this smooth operation, but none more important than steam traps. Yet, despite their critical function, the majority of plants rely on time- and labor-intensive manual inspections. Yet, with the emergence of industrial Internet technology, steam traps make ideal candidates for automated sensing technology.

Steam traps are designed to discharge unwanted condensate. They are critical components to the vast steam systems utilized worldwide for manufacturing, power generation, heating, cooling and sterilization processes. Despite their prevalence, these valves are notoriously faulty. According to estimates by the U.S. Department of Energy, “in steam systems that have not been maintained for three to five years, between 15% to 30% of the installed steam traps may have failed.” Failed traps represent not only immediate wasted energy—on the order of billions of dollars annually—but also the costly risk of production downtime, employee safety hazards, legal exposure and increased CO₂ emissions.

Cost of a Failure

Unless a plant sticks to a rigorous schedule of inspecting, maintaining, repairing and replacing steam traps across the facility, the plant is almost certainly wasting significant amounts of the costly energy its steam system produces every day.

Worse, if a plant doesn't have a regular trap maintenance process in place, it is likely to experience more trap failures. This also adds considerably to a plant's costs and could result in expensive, facility-wide downtime or even an explosion.

A single failed trap can cost a plant thousands of dollars per year. For average-size facilities with several hundred or thousands of traps, the costs accumulate quickly. More catastrophic "cold" or "closed" failures can result in process or plant-wide downtime on the order of *millions* of dollars.

Take for instance the 2007 explosion under New York City's Grand Central Terminal that is still making its way through the courts. The explosion killed one person, injured dozens of others and "created panic in Manhattan." The cause? Con Edison, the utility company that operates the city's steam distribution, described it as a combination of rainwater buildup around a pipe and clogging inside a steam trap.

Of course, massive explosions like the one under Grand Central Terminal don't happen often, but failure to meet best practice standards for maintaining steam traps continually racks up less catastrophic costs with varying degrees of liability and risk—including employee safety, CO₂ emissions, water waste—lurking just beneath the surface.

Still, inadequate monitoring is all too common due to the hassle of manual inspections and, for those forward-thinking facilities that have experimented with wireless sensors, the challenges and costs presented by today's battery-powered solutions.

Traditional Manual Inspections Don't Work

Many large, multinational corporations do not adhere to a regular schedule for inspecting their steam traps. In fact, some might go several years without conducting physical inspections.

The U.S. Department of Energy recommends inspecting process steam traps every three months and low-to-medium pressure and high-pressure steam traps every six months. The American Institute of Chemical Engineers estimates the cost of physical steam trap inspections to be roughly \$12 per trap, assuming approximately 1,000 traps total.

Considering the costs and complexity of manually inspecting all steam traps across a large plant, combined with the recommended frequency for conducting such an audit, it is clear why an undertaking might seem too daunting for a large organization.

First Generation Industrial IoT

Recently, some manufacturers have turned to automated condition monitoring for steam traps. This entails installing a sensor near a steam trap that can monitor the trap's health and wirelessly report that data at regular intervals to a central database or cloud-based dashboard.

The benefits of such a solution can be significant. Rather than having to schedule physical walk-throughs of the facility at specific times to inspect each steam trap — and hope the traps don't fail in-between inspections — a company can receive regular, automatic status updates on any of its steam traps or other pieces of equipment that need monitoring. This provides more seamless visibility into their equipment health and more timely alerts to problems.

Automated condition monitoring marks the first generation of the Internet of Things (IoT) for steam trap monitoring and offers modest improvements. However, it still doesn't close the gap. Up-front costs and ongoing battery maintenance associated with these sensors prevent them from being deployed en masse. Instead, sensors are deployed on a limited number of "problem" traps, which begs a separate question: How does one know which traps are the biggest offenders if all traps are not monitored?

As a presentation delivered at The International Society of Automation's 2014 Process Control and Safety Symposium and Exhibition concluded, the battery maintenance required of wireless sensors represents a drawback that somewhat offsets the benefits of the wireless cost savings. Moreover, the presentation pointed out, if a sensor's battery is not replaced at the correct interval, the sensor itself will fail. Ultimately, facility managers are not interested in trading one maintenance problem for another.

Solution: Remove the Battery

With the IoT evolving, improvements in sensing technology, energy harvesting, low-power wireless networks and data analytics have paved the way for completely battery-free sensors, introducing more economical and logistically feasible solutions for steam trap monitoring. Advances in circuit design and wireless communication have allowed sensors to generate power entirely from low-levels of readily available ambient energy (*e.g.*, hot steam pipes or indoor light), thus removing the battery altogether. Layering networking and software analytics on top of the newly collected data yields a simple, easy-to-use system that delivers the insights sought by facility managers without any added maintenance.

With battery-free sensors, a plant is able to realize all of the benefits of continuous steam trap monitoring with a dramatic reduction in the labor needed for inspection and repairs and with significant improvements in the quality and frequency of the data.

References

1. U.S. Department of Energy, Energy Efficiency & Renewable Energy, Advanced Manufacturing Office. *Energy Tips: Steam*. https://www.energy.gov/sites/prod/files/2014/05/f16/steam1_traps.pdf
2. Trotta, Daniel. "Clogged Valve Cited in New York Steam Pipe Blast." *Reuters*: December 27, 2007. <https://www.reuters.com/article/us-newyork-explosion-cause-idUSN2742170720071227>
3. Chen, David W. "New Questions About Who Is to Blame for Steam Pipe Explosion." *The New York Times*: July 18, 2017. <https://www.nytimes.com/2017/07/18/nyregion/steam-pipe-explosion-con-edison.html>
4. Fuhr, Dr. Peter. "Easy Ways to Save Energy Now – Take Care of Those Steam Traps." *Save Energy Now Webcast Series*. U.S. Department of Energy, Energy Efficiency & Renewable Energy and Wi-Fi Sensors, Inc. https://www.energy.gov/sites/prod/files/2013/11/f4/webinar_steamtrap_2010_0605_0.pdf
5. Walter, Jonathan P. "Implement a Sustainable Steam-Trap Management Program." *American Institute of Chemical Engineers CEP Magazine*: January 2014.
6. Sereiko, Paul and Werb, Jay. "Industrial Wireless Instrumentation Adoption Considerations." South Houston, Texas: *ISA Process Control and Safety Symposium 2014*. https://isa100wci.org/en-US/Documents/Presentations/ISA_Symposium_2014_Paper_jpw_13Aug.aspx

“A single failed trap can cost a plant thousands of dollars per year”



Brian Alessi is the Director of Product Marketing & Business Development at PsiKick, a technology company that designs and deploys completely battery-free sensors for a range of industrial assets. Brian drives product positioning and messaging, customer development, and overall go-to-market strategy and works closely with customers responsible for maintenance and reliability, innovation initiatives, and overall plant management. www.psicick.com



The RELIABILITY Conference™

MAY 6-10, 2019 • SEATTLE, WASHINGTON

**SAVE
\$200**
Register 2/28/19

Co-located with Maintenance 4.0 Digitalization Forum, The RELIABILITY Conference is designed for those who lead, manage and contribute to a reliability and asset management program. Reliability leaders, asset condition management experts, asset and maintenance managers will deliver information you can put to use immediately.

CO-LOCATED WITH **MAINTENANCE 4.0** DIGITALIZATION FORUM

WHY ATTEND?

Based on Uptime Elements Internet of Things Knowledge Domain and Digitalization Strategy Framework, the Maintenance 4.0 Digitalization Forum offers a rapid way for you and your team to explore what technologies and approaches have produced the best results while still in the early phases of technology diffusion. Explore The RELIABILITY Conference Expo where dozens of Maintenance 4.0 solution providers will be available.



WHAT IS MAINTENANCE 4.0?

A wireless vibration sensor is connected to a cloud server and machine learning platform to analyze the complex patterns and provide automated service advice to the asset owner. The vibration specialist will no longer waste time going to the data; the data, when in need of subject matter expert analysis, will go to the human. The decisions are what we call “digitally assisted,” a partnership between man and machine.

VS

MAINTENANCE 1.0

Highly trained specialists are sent to collect machinery vibration analysis readings on pumps, motors and gearboxes.

reliabilityconference.com



**AUGUST 6-8, 2019
ORLANDO, FLORIDA**

MaximoWorld includes a diverse ecosystem of business thought leaders, asset management experts, implementation service providers, digital pioneers, data scientists, support teams, analysts and mobility specialists with one common connection: IBM® Maximo® and Enterprise Asset Management. Discover new ideas and approaches for your asset management or IoT journey.

maximoworld.com



The International Maintenance Conference

**DECEMBER 9-12, 2019
MARCO ISLAND, FLORIDA**

IMC is acknowledged as the leading maintenance, reliability and asset management conference in the world. Experience a community of practice and knowledge that is moving beyond “why reliability?” towards effective actions that align to the business process.

imc-2019.com



RELIABILITYWEB.COM/EVENTS • 239.333.2500 • 888.575.1245

**RELIABILITY
WEB.COM**

OPENING THE LID OF THE

**ASSET
MANAGER'S**

TOOLBOX

Part 1

————— Grahame Fogel and Dean Griffin —————

Asset management (AM) is a recognized value lever for asset intensive organizations. It encompasses a broad vision of possibility and action. Within this new paradigm, AM practitioners need a new toolbox of skills, competencies and tools. This article, written in two parts, opens the lid of this asset manager's toolbox and takes a look inside.

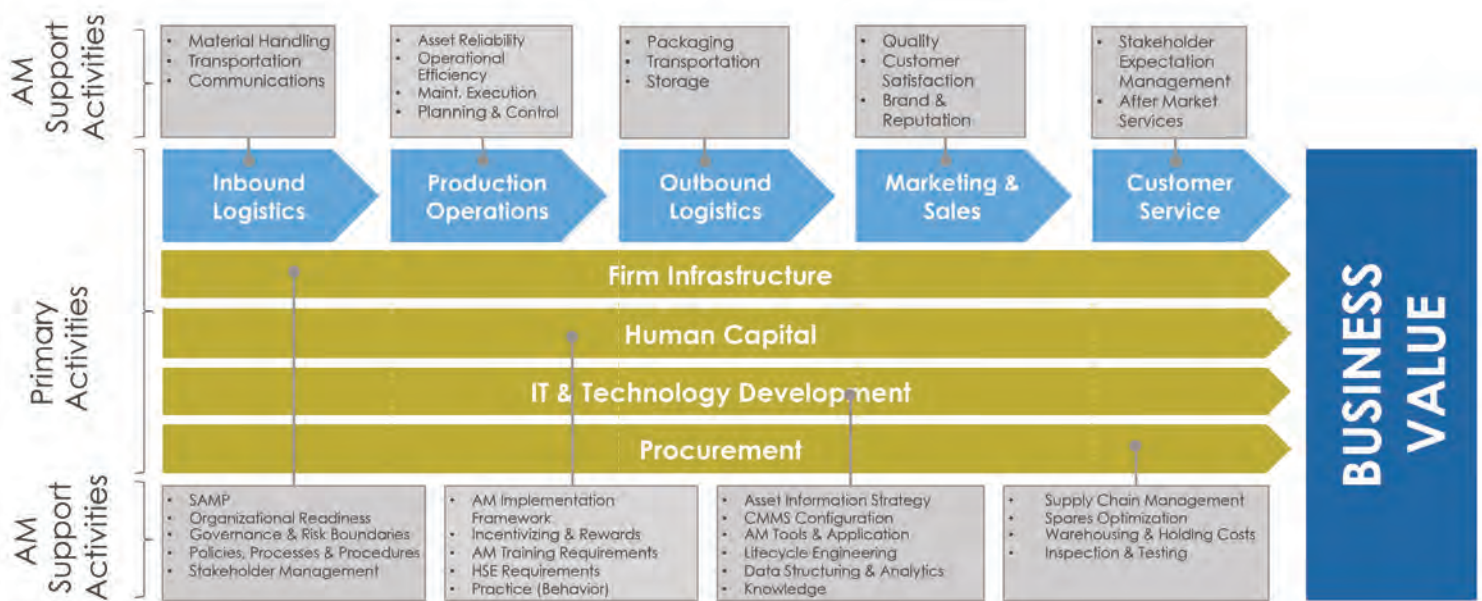

Figure 1: Mapping asset management to Porter's value model

Some AM Background

AM as a value lever gained impetus with the development of a series of ISO asset management standards in 2014 called ISO55000, ISO55001 and ISO55002. These standards conceptualize and define how organizations should structure and implement a management system for AM, simply called an asset management system (AMS). The ISO55000 series of standards articulate numerous benefits from adopting such an AMS approach. These benefits are substantiated by user experience and empirical evidence.

Two distinct concepts, namely AM and maintenance, are often confused as the same. The blurring of their roles leads to confusion and

conceptual frustration. There is a clear difference between their roles. AM encompasses a whole of business approach, incorporating numerous business functions, of which maintenance is one. Maintenance, on the other hand, is a transactional repair/restoration activity intended to optimize and prolong asset/equipment life. Both AM and maintenance are important, but a clear distinction needs to be made in order to understand their relative contribution toward delivering organizational objectives.

Asset owners and managers cannot just be specialists in specific niches within an organization. They need to develop the skills and tools necessary to see the whole picture. Moreover, they must act strategically, be able to define value and

articulate it, and understand how to pursue value in complex initiatives, which often lies across departmental and functional boundaries.

AM calls for a new set of thinking and skills aligned to what Michael E. Porter, the eminent Harvard Business School scholar, refers to as creating *shared value*. Porter argues that creating shared value is the potential new paradigm for sustainable capitalism and presents the case for organizations to create long-term sustainability. He refers to the need to transition from an exploitative to a shared value model. Within this model are three core components; the one that concerns asset managers is the second component, referred to as "redefining productivity in the value chain." Within asset intensive industries, the role of AM

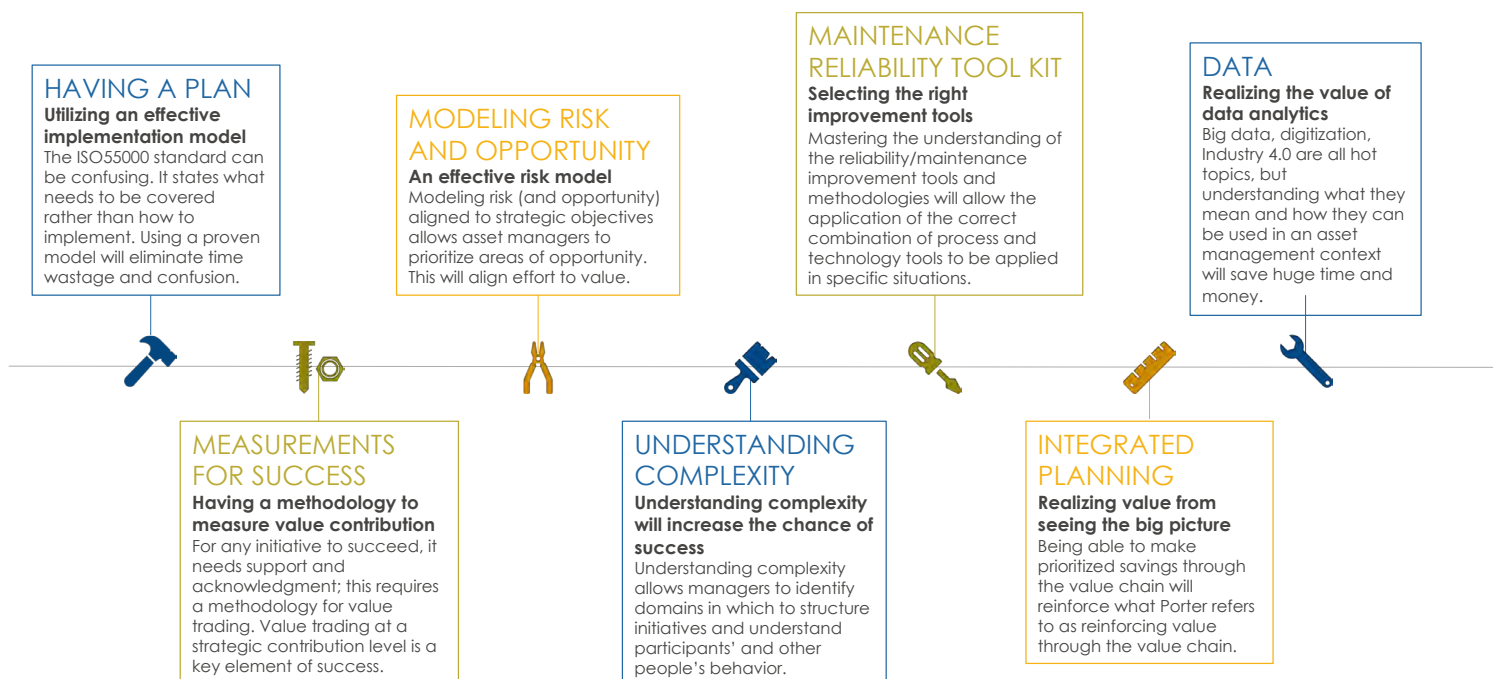

Figure 2: Asset manager's toolbox

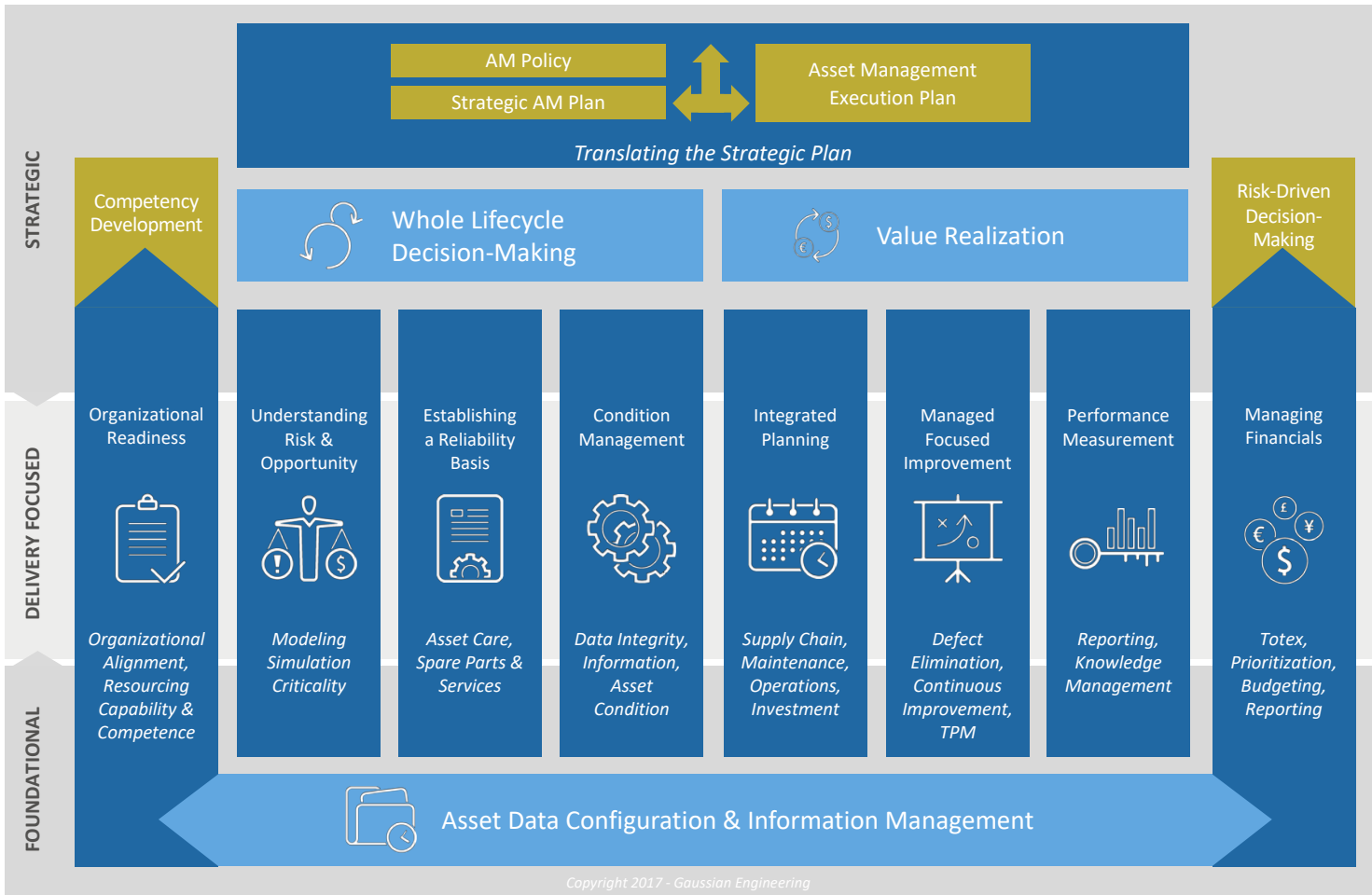

Figure 3: An effective asset management delivery model (see References, #4)

is to: direct the important strategic activities promoting effectiveness throughout the organizational value chain.

Figure 1 illustrates Porter’s value chain, where the contributions of AM enablers are mapped to the fundamentals in the value model. It clearly illustrates the areas of contribution from an AM approach. Furthermore, it clearly demonstrates the distinction between a whole business AM approach and the narrow, specific activity of maintenance, which serves to support production.

A number of important tools within this new toolbox support asset managers on their AM journey. Figure 2 provides an overview of these various tools that will be explained in the following sections.

Having a Plan: Utilizing an Effective Implementation Model

The ISO55000 series of AM standards provides a complete, albeit complex, picture of what is required from an AMS. However, many users find it too complex and difficult to translate into the nuts and bolts of what needs to be done.

Using an implementation framework, such as the effective asset management delivery model in Figure 3 or “Asset Management – An Anatomy” by the Institute of Asset Management (IAM), will assist in creating a clearer pathway toward execution.

AM predominantly fits into the complicated, complex and chaotic domains (see section on Understanding Complexity in Part 2). Establishing an AMS using a proven delivery model will significantly shorten the development and implementation period, while allowing those organizations with elements of a system in place to clarify their understanding of requirements, gaps and opportunities.

Measurements for Success: Having a Methodology to Measure Value Contribution

According to ISO55000, AM enables an organization to realize value from the ownership of assets through the achievement of organizational objectives. What constitutes value is a weighty topic and varies from organization to organiza-

tion. Inevitably, within the value argument, there is a financial component. However, in his review of the emerging redefinition of the value chain, Porter states there are many additional elements that contribute to the value paradigm. While the financial component is clearly important, there are many examples where a singular view on short-term financial criteria within the AM arena can lead to value erosion. Clearly, there is a need to redefine the whole financial value evaluation criteria so it provides the appropriate view of whether AM is creating or destroying value.

A number of financial indices measure the erosion or creation of value. However, the one that best reflects the combined efforts of an organization in influencing the creation of long-term financial value is return on invested capital (ROIC).

Practical experience has demonstrated that this is the most appropriate metric because it is a reflection of pure value erosion or creation by a management team over time. An increasingly positive trend is what one is looking for here, as it consolidates all the various efforts of an organization, from both an operational and capital deployment perspective.

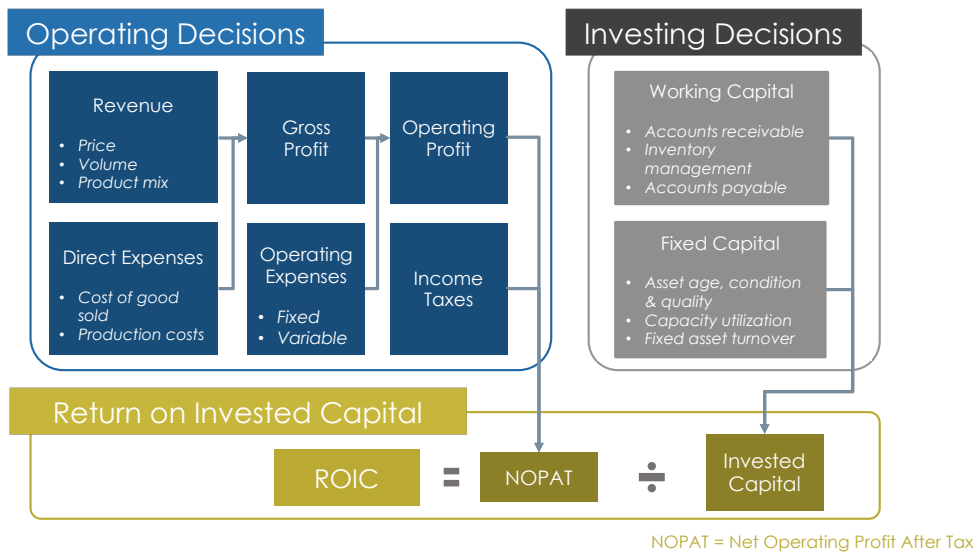

Figure 4: Measuring the effectiveness of an asset management program

The implication is that a good AM program will result in an increasing trend in ROIC, a downward trend will indicate value destruction and a flat trend will indicate a static situation. The ROIC value can be compared to industry and geographical benchmarks to ascertain whether the organization is better or worse than the competition.

Experienced practitioners often find that shop floor actions and plans are often disconnected from the boardroom's measures or objectives. For example, what is the value of redefining a production planning system or implementing TPM activities and how is that reflected in return on equity (RoE) or ROIC? Coupled to this is the complexity of organizational maturity.

A tool, like the asset management contribution model shown in Figure 5, can help link the shop floor to the boardroom. The tool is populated with organizational maturity derived through an appropriate assessment, key business performance and financial measures. Once populated, it

allows an organization to run scenarios to identify where improvement or savings must be made. Incorporating maturity guidelines allows the tool to identify areas where improvement must be made, but issues warnings when the maturity of the organization is too low to perform the initiatives or sustain them.

Change is easy, sustainable change is a different matter. Once the team has identified improvement areas, initiatives identified through analysis and assessment can be tailored, prioritized and implemented. Not quite the mythical business crystal ball, but as close as you can get to it.

The bottom line is the tool allows organizations to clearly align initiatives to measurable value contribution. This is a big-time credibility enhancer and effort saver.

Conclusion

In Part 1 of the 2-part article we have looked at two key asset management enablers:

1. Having a Plan – Utilizing an effective implementation model
2. Measurement of Success – having a methodology to measure value contribution

As can be seen, these are strategic enablers that apply across the business, not just in the maintenance department, and as such, contribute to real strategic value.

In Part 2, we will look at:

1. Modeling Risk and Opportunity – an effective risk model
2. Understanding Complexity – how understanding complexity theory will enhance your chance of success.
3. The Maintenance Reliability Toolkit – selecting the right improvement tools
4. Integrated Planning – seeing the “big picture”
5. Data – realizing the value of analysis

References

1. International Organization for Standardization (ISO). *ISO55000:2014 Asset management – Overview, principles and terminology*. <https://www.iso.org/standard/55088.html>
2. Porter, Michael E. *Competitive Advantage: Creating and Sustaining Superior Performance*. New York: Free Press, 1998.
3. Snowden, David J. and Boone, Mary E. “A Leader’s Framework for Decision Making”. *Harvard Business Review*, November 2007: pp 69–76.
4. Fogel, G. and Swart, P. “Does Relying on Criticality Put Your Organization at Risk?” *Uptime Magazine*, April/May 2018.
5. Fogel, G., Stander, J. and Griffin, D. “Creating an Effective Asset Management Delivery Model”. *Uptime Magazine*, June/July 2017.
6. Fogel, G. and Kemp, T. “The Role of Asset Management in a Constrained Economy”. *IAM Annual Conference*, Edinburgh, Scotland: 2016.
7. Fogel, G. and Swanepoel, S. “Chapter 8: Declaring Value from an Asset Management System.” *The New Asset Management Handbook*. Fort Myers: Reliabilityweb.com, 2014.



Grahame Fogel is the founder of Gaussian Engineering. He is an experienced International Consultant in the field of asset management. He is a recognized subject matter expert in the fields of strategic asset management, reliability engineering, condition monitoring and change management within the asset intensive industries. www.gauseng.com



Dean Griffin is a thought leader in the area of asset management and contributes significantly in understanding the business effects of asset management. He is Chairman of the South Africa Mirror Committee for TC251 and has contributed significantly to the ISO55000 standard. Dean is a Director of Gaussian Engineering. www.gauseng.com

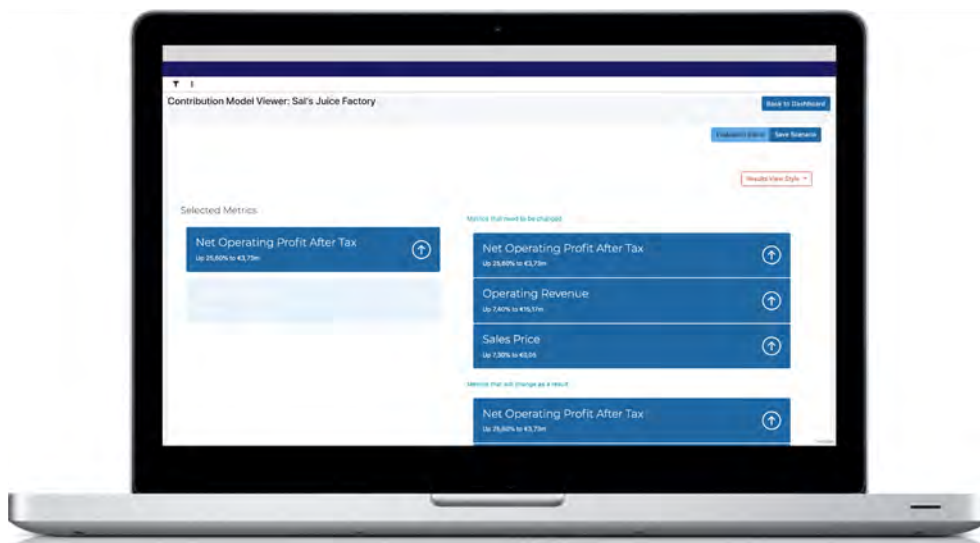
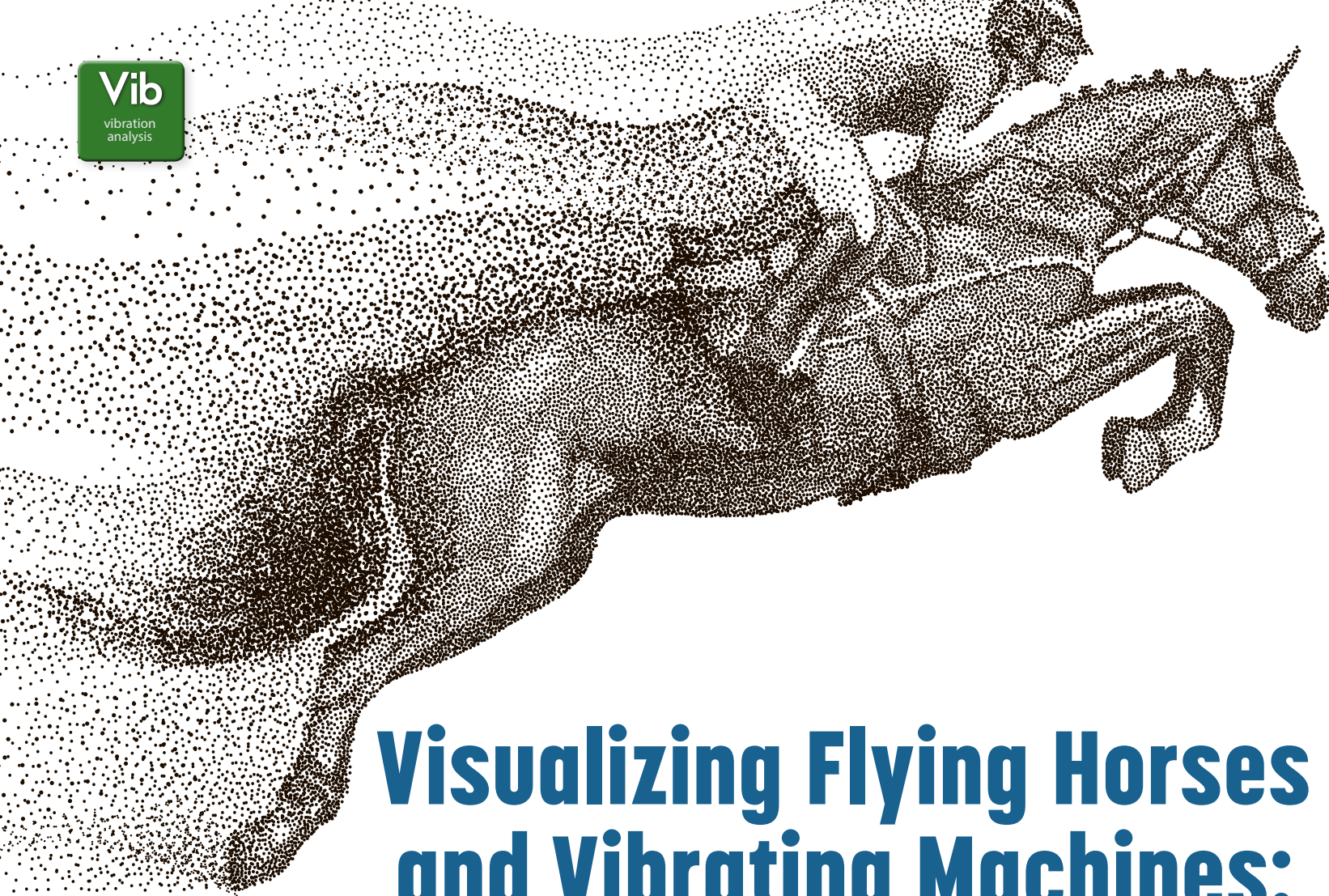

Figure 5: Example of an asset management contribution model



Visualizing Flying Horses and Vibrating Machines:

Slow-Motion Amplified Video

Chad Pasho

“HORSES DO,
INDEED, FLY”

In the early 1800s, a new technology was developed that visually captured a snippet of time. Before this, people wanting to memorialize an image were dependent on drawings, which were subject to the artist's attention to detail, interpretation and nuance. This 1800s camera could render a “photograph,” albeit crudely, that exactly and automatically represented what people saw at that particular moment. And it wasn't long before this technology was deployed to further understand objects in motion by sequencing photographs in what we understand today as video. This laid the foundation for visualizing vibration using high-speed video, a technology that is revolutionizing the way organizations today interpret machinery motion.



Figure 1: Muybridge captured horse “flight” in 1878 using high-speed photography to understand objects moving too rapidly for the human eye to perceive

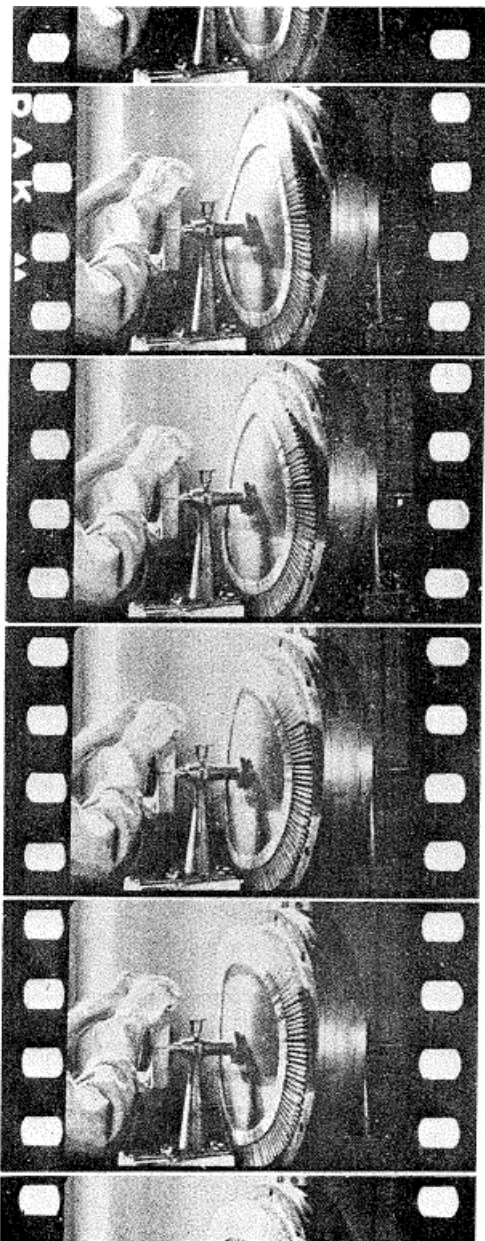

Figure 2: Campbell's high-speed photography provided a comprehensive understanding of rotating disk vibration behavior

See a Man About a Horse

In 1878, Eadweard Muybridge used videography to settle the burning debate of his time: can horses fly? Leland Stanford, previous railroad magnate and governor of California, commissioned Muybridge in 1872 to determine if horses engaged in "unsupported transit," in which the horse would be entirely airborne without a foot in contact with the ground. After a brief hiatus, during which Muybridge murdered his wife's lover, was found not guilty on account of justifiable homicide, and spent a year in Central America in "working exile," he eventually rigged a series of 12 cameras and an ingenious trigger system to capture one of Stanford's galloping horses. The results

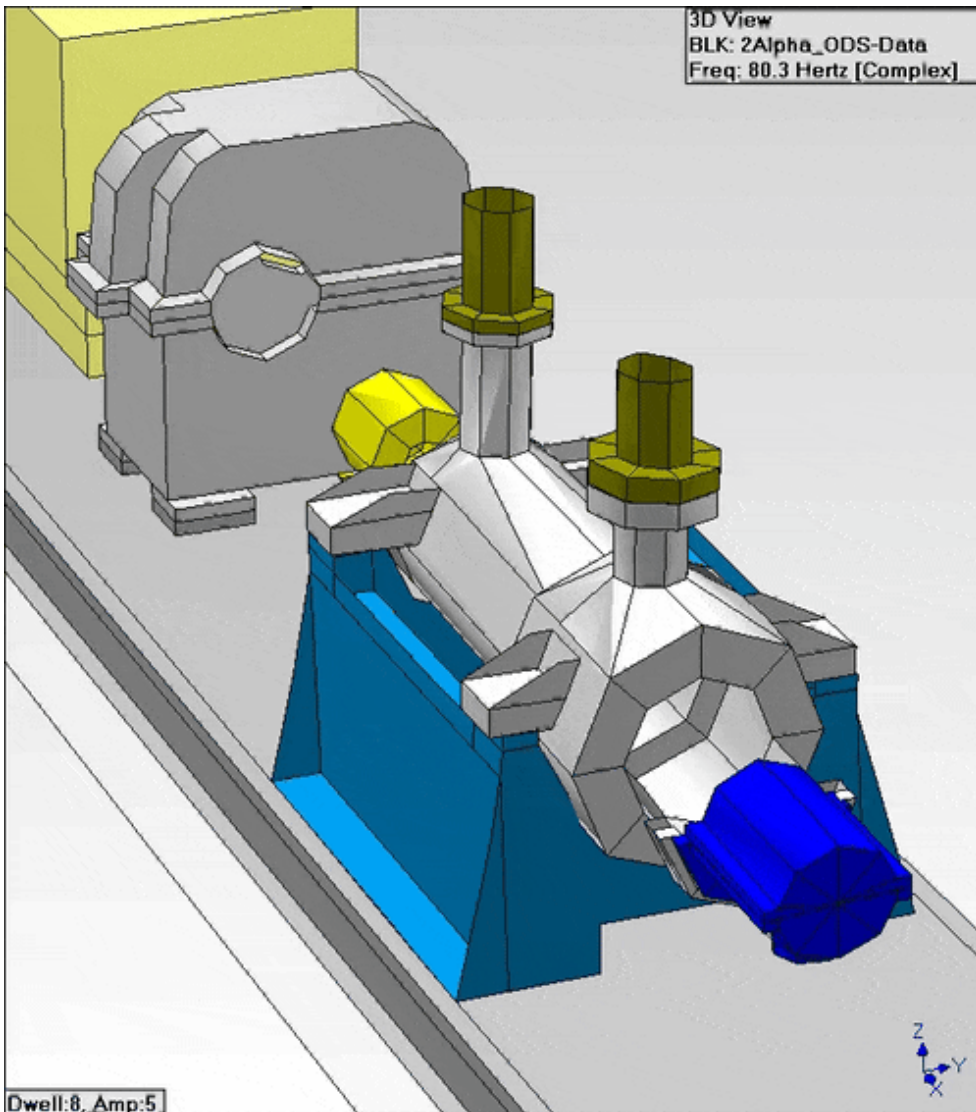

Figure 3: Accelerometer data compiled into a graphical representation of the machine and then amplified at specific frequencies to highlight problems; In this case, a soft foot condition exists where the casing attaches to the pedestal, enabling a resonance condition at running speed

were conclusive and upended the accepted understanding of the day. Horses do, indeed, fly.

How Campbell Got His Diagram

In 1924, Wilfred Campbell presented his research in turbine vibration to the American Society of Mechanical Engineers. At the time, many in the industry believed that steam turbines had reached their maximum size, given limiting factors, such as vibration. In his pioneering paper¹, he laid the framework for the famous Campbell diagram, which modeled vibrational behavior of a rotating disk and provided an understanding that enabled breaking through design boundaries. Truly a man before his time, he employed high-speed photography to capture the floppy behavior of a vibrating, rotating disk and showed the mechanical world a phenomenon they could now comprehend. Sadly, this was his swan song, as just over a month after the conference at which

he presented his paper, tragedy struck and acute appendicitis took his life at only 40 years of age.

Vibration Visualization – Data-Driven Cartoons

In the 1960s, the algorithm known as fast Fourier transform (FFT) took the vibration world by storm. In an effort to detect nuclear testing in the Soviet Union, John Tukey proposed the means to extract and quantify frequency domain information from a time domain vibration signal. The following decade, this algorithm was applied to vibrating objects to understand their relative shape during movement, known as operating deflection shape (ODS). This powerful model is created by sampling vibration data at multiple points on a vibrating object. A graphical model of the object is built and the vibration data gathered from each point on the machine is applied to its place on the model. The motion for specific frequencies is then

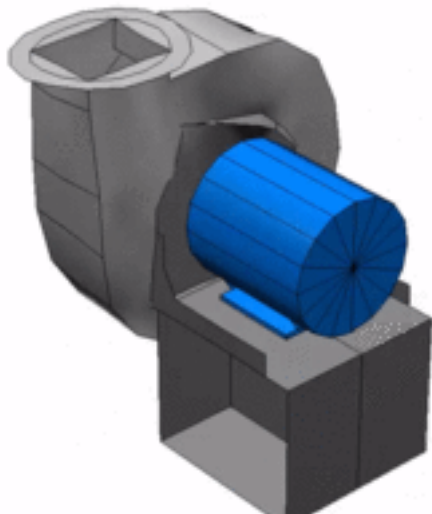

Figure 4: ODS analysis clearly shows a resonant mode at 474 Hz, where the housing undulated like a speaker cone, however, it took hundreds of data points and two days of careful work to reach this conclusion

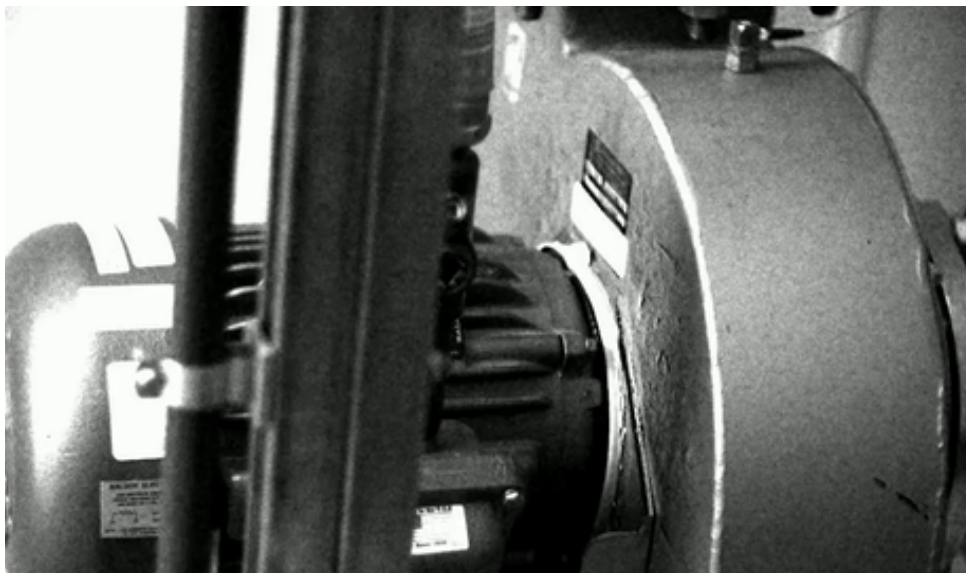

Figure 5: Motion amplified video displays same undulating motion of the housing as Figure 4, but took minutes to reach the same conclusion with a much more detailed and realistic image

“...Vibration information can be extracted pixel-by-pixel from the image”

amplified and animated, providing a visual model for interpreting the behavior or “shape” of the object’s motion.

Since that time, ODS has become a fundamental tool for troubleshooting rotating machinery. It facilitates the understanding of machinery modes of movement for frequencies at which force is being applied to the machine. For example, the rotational speed of a machine commonly adds force at a frequency equal to one times the operating frequency. The resulting deflection shape can be easily observed at this frequency by amplifying and animating the motion, and often certain faults can be quickly diagnosed based on the shape of the motion.

As a real-world example, a high-pressure charge pump was experiencing excessive vibration at a U.S. nuclear power plant. This pump runs at 4,800 rpm (80 Hz), driven by a 1,800 rpm motor through a speed increasing gearset. ODS samples were obtained tri-directionally at 200 locations on the pump, pedestal and foundation. The detailed study determined significant lateral vibration in the horizontal direction on one of the pump’s non-drive end (NDE) mounting feet, versus the top mounting surface of its pedestal, at the pump’s operating frequency, or 80Hz.

The diagnosis involved the casing’s structural (as supported by the pedestal) natural frequency

(involving horizontal swaying of the casing’s NDE end). It used to be 15 percent above the running speed, which typically was sufficient to avoid getting excited. But now, it was drifting down into and sometimes beyond the running speed of the pump, tuning in a resonance. The reason for the downward shift was when the foot was able to slide in frictional contact, it no longer supplied as stiff of a support to the casing. By tightening down on the foot attachment bolt, this soft foot condition was repaired and the natural frequency involved shifted back up to around 93 Hz, sufficiently separated from 1x running speed forces (e.g., residual imbalance) to avoid further resonance. Vibration levels decreased to very acceptable levels.

The physical problem may seem trivial once its nature is perceived. However, some very good technical people at the plant wrestled with this problem for six months before a vibration visualization technique – in this case ODS – was applied. The perspective on the vibration distribution and its meaning was not there when the plant evaluated the vibration data point by point instead of as a comprehensive set of points.

Once it was employed, ODS was extremely useful in this case, rendering a diagnosis of the problem that led to a recommendation of a straightforward solution. It has proven over de-

acades of applications that it is a powerful and intuitive diagnostic tool capable of clearly demonstrating modes and frequencies of vibration.

However, ODS has its drawbacks, as well. For example, it can be time-consuming. In data acquisition, the hundreds of data points still require considerable interpolation between points. In post processing, it takes time to compile a database to match model points. There is also the potential of bookkeeping errors when matching all the gathered data points to the appropriate place and direction on the model. Lastly, ODS requires proximity, which might not be appropriate for restricted access where there are heat, radiation or accessibility/scaffolding requirements.

And let’s face it, an ODS is still a cartoon – a coarse, albeit generally understandable, artist’s rendering of a snippet in time of a machine’s operation. Sound familiar?

Vibration Visualization – Data Enhanced Video

Just as the photograph captured what people saw, high-speed video is now enabling the capture of rotating machinery motion. But, this motion is typically too small and too fast for people to see. However, by applying algorithms as groundbreaking as the previously mentioned FFT, vibration information can be extracted pixel-by-pixel from the image. This is the equivalent of millions of accelerometers providing frequency and amplitude information in a genuinely comprehensive fashion. The information then can be amplified and integrated into the original video, pixel-by-pixel, providing an enhanced video that

fuses the helpful amplification of the ODS with real-world, detailed imagery – and without the drudgery and potential for error of an ODS.

Let's turn to another example of the technology in action to demonstrate its power. Two small, constant speed (3,600 rpm) ducted fan blowers required for worker ventilation at a wastewater facility were exhibiting normal levels of vibration, but were running loud. And loud in this case was as high as 120 dB at an audible tone of 474 Hz, which just so happened to be the blade pass frequency. To get an idea of how loud that is, picture yourself at a rock concert in front of the speakers without the catchy tune. Data for an ODS was gathered, as well as a high-speed video for vibration amplification analysis.

Once the mode shape was identified and evaluated, it was clear that the blower was in resonance with the blade passing frequency of 474 Hz. The upper sidewall of the casing possessed a "plate mode" natural frequency very close to the blade pass frequency. As the blower underwent changes in loading, the induction motor slip changed and the vane passing frequency drifted into and out of precise resonance with the sidewall natural frequency, causing the mysterious loud noise.

This new video-based motion amplification technology can be very useful for vibration-based

diagnosis of machinery. It has advantages over the classic ODS method in many, but not all, instances and typically takes much less time and logistics to implement.

Like ODS, it is a powerful and intuitive diagnostic tool that is easy for non-experts to understand. It realistically demonstrates modes and frequencies of vibration. But unlike ODS, it can create a comprehensive set of data points without the need for expert selection and bookkeeping. Additionally, millions of data points are ready to evaluate in minutes, not days.

Unlike ODS, video-based motion amplification technology does not require contact, which makes it appropriate for restricted areas involving heat, radiation or accessibility/scaffolding requirements.

The technology is also cost-effective. It is inexpensive as the sole troubleshooting technology, or it can help to focus the effort for accelerometer-based ODS.

On the Market Today

Presently, there are at least two commercialized methods for obtaining amplified vibration from video: Lagrangian (watch speckles or features move) and Eulerian (watch fixed location pixel intensity change). For most low speed machin-

ery issues, either method is adequate. For higher speed machines and high frequency problems, such as vane pass noise, the Eulerian method may be more practical, permitting greater amplification of motion, so long as there is comparable cost and system complexity.

Video

View related videos from this article:
<https://uptime4.me/2FP0AOv>

References

1. Campbell, Wilfred. "Protection of Steam Turbine Disk Wheels from Axial Vibration." The American Society of Mechanical Engineers, Paper No. 1920, 1924.



Chad Pasho is the Business Development Manager for Envision Motion, providing vibration analysis and visualization tools that utilize high-speed video. His industry experience includes oil and gas exploration

and nuclear power, as well as general rotating machinery troubleshooting domain knowledge with Mechanical Solutions, Inc.
www.envisionmotion.com

DOES YOUR COMPANY HAVE A PLAN TO PROTECT AND MAINTAIN YOUR CRITICAL EQUIPMENT? WE CAN HELP.

TECHNICAL ASSOCIATES OF CHARLOTTE SERVICES



Over 150 years of combined Vibration Analysis, Training, and Engineering support in over 20 different industries around the world!



www.technicalassociates.net

704.333.9011

1230 West Morehead Street, Suite 400
Charlotte, NC 28208



TABLE 2 – Job Plan with Hazards and Mitigation

STEP NUMBER	ACTIVITY	HAZARD	STEPS AND PERSONAL PROTECTIVE EQUIPMENT (PPE) TO MITIGATE
2	Shore up discharge section	Entrapment and crushing, Falling objects	Mitigate adequate design, hard hats, steel toe boots
3	Drain and blind	Airborne contaminants, Asphyxiation, Chemical ingestion, Skin exposure, Breathing, Eye damage (e.g., particle, chemical, flash)	Fresh air, gloves, full body moon suit, if needed, face mask
4	Unbolt, rig and remove spool on suction side (513#)	Entrapment and crushing, Falling objects	Steel toe shoes, rigging standards, inspection of straps and chokers, etc.
5	Rig and remove pump with crane (2,350#)	Entrapment and crushing, Falling objects, Asphyxiation	Procedures to clear the lift path, formal lift plan, test air before getting too close, steel toe shoes, rigging standards, inspection of straps and chokers, etc.

Safety Data Sheets Basics

What Every Maintenance Leader Needs to Know

The most common mistake organizations make with safety data sheets (SDS) and chemicals is that the inventory of chemicals in use does not correspond to the SDS in the notebook or file. The fine in the U.S., as in other areas, runs from \$7,000 per incident per day to \$25,000 per incident per day.

To avoid being out of compliance, consider computerizing the whole process. In the U.S., the Occupational Safety and Health Administration (OSHA) accepts the presence of SDS in a computer. With networks, you can avoid trouble by having a company-wide file available to everyone.

Two important things to keep in mind:

1. It is the manufacturer of the chemical that is responsible to get the SDS to you. You are responsible to notice if you have them or not.
2. A major source of inspections originates from disgruntled employees anonymously calling OSHA.

The exact format of the SDS varies by manufacturer, but there are general sections that contain critical information that every employee should know. Some SDS could have as many as 15 parts.

The Safety Meeting

One aspect of safety is the reminder to be safe! Just the actual reminder might save someone's life. It's not unreasonable to have a safety moment every day. It could be one or two minutes. At some companies, when they have any meeting, they always start with a safety moment.

In maintenance, there's usually a five- or 10-minute section on safety during the daily toolbox meeting in the morning; nothing really elaborate. If you're going to address a bigger safety topic, it might be a half hour or an hour with a slide presentation.

It could be a single point lesson. For example, you might discuss fatigue. Fatigue is the most common cause of accidents because when you are tired, there is more of a chance of injury. Another important topic might be slipping and tripping. Slipping and tripping is the second most common cause of accidents, which can be avoided with improved housekeeping and better lighting.

“ The purpose of a JSA (job safety analysis) is to ensure that the risk of each step of a task is reduced to as low as reasonably practicable ”

OSHA has some really great material for safety meetings that you can access from its website (osha.gov/SLTC/text_index.html). This material is available to anyone, anywhere in the world. There are literally enough topics there to last a year.

Among the topics available are: confined space; disease prevention and blood-borne pathogens; electrical hazards; ergonomics; hearing conservation; ladders; hazard communications; lifting toolbox with care; rigging; LOTO; office issues; PPE; seasonal toolbox dealing with seasonal issues or holiday

TABLE 3 – SDS Highlights

Part #1	OSHA hazard	This section is an overview of the hazard. Read it carefully to determine if a significant hazard exists.
Part #3	Precautionary label information as prescribed by the U.S. Environmental Protection Agency (EPA)	These sections go through the specific first aid steps for all types of exposure, including ingestion, inhalation, skin contact, etc. If you work with dangerous materials, study these sections and be prepared.
Part #4	First aid	
Part #6	Toxicological information	While designed for doctors and scientists, a quick read through these sections will tip you off as to whether the material is very toxic or very dangerous to the environment.
Part #7	Environmental toxicology	
Part #9	Fire	This part alerts you to a potential fire hazard or a potential deadly reaction with another chemical. In some cases, mixing two safe chemicals results in an unsafe reaction. For example, the gas given off by mixing bleach and ammonia is deadly.
Part #10	Reactivity	
Other Parts	Transit, handling, spill procedures, regulation	All the other information necessary for use, transport and cleanup of the chemical.

TABLE 4 – 2017-2018 Sample of Fatalities

Clarksville	TN	Worker fatally crushed by rolling truck
Weatherford	TX	Worker died in fall from bucket of front-end loader
Austin	TX	Worker fatally crushed under bus when jacks slipped
Columbia	SC	Worker died after becoming caught between scissor lift and ceiling
South Kingstown	RI	Worker electrocuted when lift contacted power line
Hurst	TX	Worker died in fall from ladder
Maynardville	TN	Worker fatally crushed by axles while unsecuring load from trailer
Hazel Crest	IL	Worker fatally crushed under truck when jack slipped
San Francisco	CA	Worker fatally crushed between truck cab door and door frame
Harrisburg	PA	Worker died after being struck by tractor trailer
Bristow	VA	Worker died after being struck by school bus
Kailua Kona	HI	Worker died in fall from trailer
Martinez	CA	Worker fatally crushed under vehicle
Mahaska	KS	Worker died of hydrogen sulfide and carbon monoxide exposure
Baytown	TX	Worker died from exposure to vapors while cleaning tanker truck
Irving	TX	Worker died in fall from ladder

TABLE 5 – 2017 Top 10 Safety Issues

1. Fall protection, construction
2. Hazard communication standard, general industry
3. Scaffolding, general requirements, construction
4. Respiratory protection, general industry
5. Control of hazardous energy (LOTO), general industry
6. Ladders, construction
7. Powered industrial trucks, general
8. Machinery and machine guarding, general requirements
9. Fall protection, training requirements
10. Electrical, wiring methods, components and equipment, general industry

awareness; slips, trips and falls; fatigue; fire; forklifts and forklift driving; small tools toolbox for small hand or powered tools; and weather and how it affects safety.

You could also base topics on the top fatal safety incidents, as shown in Table 4, or the top safety issues in a particular year, as listed in Table 5.

Frequency for Covering Key Topics

You should cover an important topic every couple of months, perhaps covering a different aspect of it each time.

To make the topic relatable, considering telling real-life stories. Here's an example:

A guy bent over to pick up a tool and collapsed. His buddy standing next to him, thinking he's having a heart attack, bends over to help him and he collapses, too! It turned out there was a chest-high level of carbon dioxide, so as long as they were standing up, they were fine.

The problem was they did oxygen sensing at head level. If they had done it up and down their entire body, they would have known there was an issue and accommodated it.

A lot of people don't know about oxygen sensing, so using oxygen sensors correctly would be a good single point lesson. Operational experience is not helpful if you don't know the things behind it. People get hurt by all kinds of crazy stuff. Telling those types of stories is useful.

Be careful with contractors. Include them in the meetings and introduce them around. However, be aware that contractors have a unique situation compared to in-house people. Every single day, contractors are facing a different set of hazards because of the different locations. So, you want to discuss what's going on at that site. Don't begrudge them the time to look at the hazards, such as slippery surfaces, construction going on around them, the position of cranes and heavy lifts, and overhead power lines.

Keeping Records

Keep a log of topics so you know what you are covering. It is also helpful for planning your next meetings. The talks should be held on company time and cover the hazards that your organization faces. You should also keep a record of who is in attendance, such as an attendance or sign-in sheet.



One aspect of safety is the reminder to be safe... just the actual reminder might save someone's life



Why Go to All This Trouble?

- You made a promise! Check your mission, vision and value statement. Safety is one of the core promises to your employees and communities.
- Safety incidents create a bad public image.
- Compliance with regulations, laws and standards saves fines and keeps your company out of the news.
- There is an argument that safety saves money. When you consider the overall costs of accidents, a safe organization seems to always be the lowest cost producer.
- Many programs, such as 5S, increase operational efficiency and promote safety.
- People avoid having accidents and having their friends hurt. Safety might improve employee satisfaction (or at least reduce dissatisfaction).

Downloads

Shop Safety Audit and Inspection Forms: uptime4.me/2UluFZh

References

1. Checklist adapted from and courtesy of HP Hood LLC, through American Society of Safety Engineers www.asse.org/practicespecialties/transportation/
2. Canadian Centre for Occupational Health and Safety. *OSH Answers Fact Sheets: Inspection Checklists – Sample Checklist for Manufacturing Facilities*. https://www.ccohs.ca/oshanswers/hsprograms/list_mft.html
3. Work Safe Victoria, Australia. *Tools to Help You Create a Safe and Healthy Workplace*. <https://www.worksafe.vic.gov.au/>
4. U.S. Department of Labor, OSHA. *QuickTakes online bimonthly newsletter*. osha.gov/as/opa/quicktakes



Joel Levitt, CRL, CPMM, is the President of Laser Focused Training. Mr. Levitt has 30 years of experience in many facets of maintenance, including process control design, source equipment inspector, electrician, field service technician, maritime operations and property management. He is a leading trainer of maintenance professionals and has trained more than 17,000 maintenance leaders from 3,000 organizations in 25 countries in over 500 sessions. www.maintenancetraining.com



The 23rd Annual Reliability and Maintainability Conference

Knoxville, TN • March 4 – 7, 2019

Bring your entire team to MARCON. Buy 3 and the 4th registration is FREE! We can even host your team meeting!

- 13 Pre-Conference Workshops
- 3 Keynote Presentations
- 3 Tracks of Paper Presentations (70% Practitioners)
- Exhibit Area Featuring the Leading R&M Providers
- Two Networking Events

www.marcon.utk.edu



Technologies That Make ASSET MONITORING Boring (In a Good Way)

Brett Burger

A call about a line outage or a message from an operator that “something’s wrong” is not a good start to the day. Early warning signs are there to be found. However, maintenance engineers can’t be everywhere at once. Time between data rounds is when something can go wrong, and some equipment isn’t even on a data collection route.

Many experienced maintenance professionals are at or near retirement age. With fewer replacements on the horizon, manufacturers are increasingly looking to industrial technology to maximize worker productivity to unlock capacity and improve overall equipment effectiveness (OEE). Better uptime starts with better data. These four technologies help provide better data quality and access to the teams that keep plants up and running.

Cloud- and Web-Based Software Technology

Isn’t it odd that monitoring professionals walk routes between equipment to gather data, yet there is consumer technology on the market to see inside a refrigerator from a cell phone?

This technology exists for turbomachinery. Analysts can decide which plant, line, or asset they need to visit to best impact reliability before grabbing their hard hat or car keys. The goal of re-

mote diagnostics is to provide data that, as much as possible, alleviates the need for analysts to be on-site. The concept is simple: connect sensor data to an IT network so experts receive asset health data through a web browser, rather than traveling to collect data with handheld instrumentation and their own senses.

It’s important to note the distinction in data types needed for remote diagnostics. Many sys-

tems report overall feature calculations (e.g., root mean square (RMS), peak-peak, 1X/2X magnitude, and so on) and others report full waveform data. Overall, feature calculations alarm on general problems and are used to identify *some* failure modes. But, feature alarms need a follow-up with waveform data, typically captured by handheld devices, for more in-depth analysis, as seen in Figure 1. If waveform data is the goal, the systems



Figure 1: Vibration measurement layout showing RMS trend line, waveform, spectrum and envelope analysis



Figure 2: Software technology converts raw, digitized accelerometer data into an audio file so analysts can listen for problems from across the factory or across the country

that connect waveform data to the Cloud are the ones that most effectively improve productivity.

Web access to waveform data and analysis helps experts remotely diagnose asset health. At minimum, remote analysis provides peace of mind without involving road trips, catwalks, ad hoc plant walk downs, or calls to the expert who is currently out of town. In some cases, remote analysis can prevent a profit draining outage.

Vibration data is one of the primary measurements for asset health, but it's not the only sensor technology used to diagnose problems. Oil analysis, motor current signature analysis, infrared thermography, electromagnetic signature analysis, and others are used to capture a broader range of

failure modes and conduct differential diagnosis. It is important that server software for asset monitoring manages data from multiple sensor technologies. This way, analysts can have more confidence in their remote diagnosis and know where to best focus their time. A more critical piece of equipment may be less of a risk to uptime than a less critical asset with a more devastating issue.

Experienced analysts use their senses to help diagnose equipment problems: does the machine sound, smell, or look off? Software technology exists to convert digitized accelerometer data into an audio file (Figure 2) so analysts can listen for problems as if they were standing in front of the equipment.

“It is important that server software for asset monitoring manages data from multiple sensor technologies”



Figure 3: Wireless instrumentation shown connected to standard, piezoelectric accelerometers reduces the cost of high quality waveform data

Wireless Instrumentation

The biggest cost driver for permanently installed instrumentation is typically installation, including engineering design and a contractor to run conduit for power and Ethernet. Transmitting sensor data wirelessly greatly reduces this cost.

From a communication standpoint, there is no silver bullet. A wide variety of wireless standards and protocols (e.g., Bluetooth, Wi-Fi, ISA100, WirelessHART, LoRa, and several 900 MHz variants) can help vendors assemble wireless instrumentation to cost-effectively pull vibration data from 20 year old pumps, motors, fans and other assets.

Advancements in sensor digitization components, such as analog-to-digital converters, are bringing waveform quality data from the same piezoelectric sensors used with portable systems. These, however, are permanently mounted to the asset and wirelessly connected to an IT network to reduce or eliminate the need for routes (Figure 3).

Microelectromechanical Systems (MEMS)

Silicon technology companies designing MEMS sensors for mass markets, like gaming consoles, consumer automobiles and smartphones, are using that same design expertise to target industrial markets. MEMS sensors, like most electronic technologies, are continuing to shrink, use less power and provide higher quality measurements. This makes them a good fit to measure vibration data for machine health.

Most MEMS sensors for condition monitoring (Figure 4) are complete with a sensor, signal digitization circuitry, if needed, a battery and wireless radio, all built into mechanical packaging for a specific operating environment. To install, the main difference from installing traditional piezoelectric sensors is the need for a few gateways installed around the plant.

Many MEMS vibration sensors are triaxial and include a temperature sensor. This makes them a relatively low-cost way to connect problematic assets that otherwise wouldn't be worth adding to a collection route or running conduit to. Instead of having data visibility on only the top five percent of plant assets, maintenance teams can cover the top 20 percent of assets most likely to have issues and contribute to downtime risk.

Edge Processing Technology

Asset health data is big data. A single pump motor skid with a few triaxial accelerometers connected to permanent instrumentation can generate over 20 GB of data per day. The Cloud essentially has infinite processing capability, however, a plant can't feasibly push all its sensor data to the Cloud for processing.

Technology vendors in the condition monitoring market are packaging the latest in processing elements into rugged, passively cooled devices.



Figure 4: MEMS-based sensor connected to a vertically installed motor wirelessly sends data to experts for analysis

es to help manage large amounts of raw sensor data before it leaves the plant floor. Most data from manufacturing equipment is benign and, if recorded, would serve only to bog down analysts as they seek the important artifacts within. Smart

monitoring devices screen the data looking for predesignated features. When these features, such as RMS or crest factor limits, are found, the data is logged and sent to the server software for access by an analyst.

Route-based acquisition records data at a predesignated time, regardless of asset health measurements. Twenty-four hours after an asset is measured, it could start showing signs of bearing wear that wouldn't be caught until the next route three months later. By contrast, continuous monitoring equipment records data for a predesignated feature, so teams only get the data they want.

Data captures from start-ups hold valuable information, but can be logistically difficult to acquire. Getting the right person with the right instrumentation in front of the asset at the right time can be difficult. This is especially true when manufacturers have more plants than reliability experts and more reliability experts than instrumentation. On top of those logistics, some start-ups are unplanned (think peaking units for power generators or auxiliary equipment).

Edge processing technology helps manage the big data of asset health monitoring. By continuously acquiring and screening data, maintenance teams have less data containing more information to analyze, which makes more efficient use of their time.

Making Days Boring

Analysts need to take their expertise on-site to the plant. Asset monitoring technology is not replacing their years of experience in keeping turbomachinery spinning. Rather, it's helping them spend less time collecting data and filtering through useless data and more time focusing on the equipment most likely to cause the next outage. Getting ahead of these problems prevents the excitement from calls about outages and operator messages regarding odd equipment behavior. It makes overseeing equipment boring. But in a good way.



Brett Burger is the Principal Solution Marketing Manager for Online Monitoring at National Instruments (NI). He has experience in a variety of fields, including machine condition monitoring, smart grid technology, sensors, and data acquisition. Brett has been deeply involved with NI's Industrial Internet of Things (IIoT) and showing the value engineers can offer businesses through intelligent, connected, data-centric systems. www.ni.com/en-us.html



NO EXCUSES

FOR MISALIGNMENT



Misalignment leads to increased vibration, premature seal, belt or bearing failures and increased power consumption. There's no excuse to let misalignment cost you money. Protect your machines and minimize costly downtime through precision laser shaft and belt pulley alignment. Our equipment and support are the industry benchmark. **Keep it Running™**.

305.591.8935 | www.KeepItRunning.com



EASY-LASER® Generation XT
Cross-Platform for Shaft and Belt Alignment



LUDECA

SDT340

CLOUD CONNECTED
CONDITION MONITORING

with Ultranalysis Suite 4

Detect, measure and analyze
ultrasound and vibration



Mechanical



Leaks



Electrical



Lubrication



Valves



Hydraulics



Steam



Tightness

sdtultrasound.com/sdt340



Ultrasound Solutions
1-800-667-5325



LUDECA

Exclusive U.S. Partner for Sales & Service



WHAT HIDES BEHIND THE TERM:

LEAN MAINTENANCE

Those familiar with the application of lean principles have come across terms like: lean manufacturing, lean enterprise and lean organization. But lean maintenance is not as commonly discussed as the other three terms.

Why is that?

Some consider lean maintenance as merely a subset or spin-off of lean manufacturing. In reality, however, that is not the case. Lean maintenance is actually a precondition for the success of lean manufacturing, rather than just an accessory.

This article explains the basic fundamentals of lean maintenance and presents a few of its benefits and challenges.

WHAT IS LEAN MAINTENANCE?

Lean maintenance is a management strategy that aims to apply lean principles and goals to physical asset management.

The ultimate goal of lean thinking is to provide perfect value to the customer through processes that generate zero waste. In this context, waste refers to the use of resources (e.g., time, labor, inventory, energy, etc.) in any way that does not add value to the final product or service.

By applying these same lean goals, lean maintenance results in improved productivity and reduced costs, while also relying heavily on practices inherent in total productive maintenance (TPM) and reliability-centered maintenance (RCM) to be effective.

Foundational Elements of Lean Maintenance

It's easy to understand why many still wrongly classify lean maintenance as a subset of lean manufacturing. After all, many of the tools used to implement and sustain lean manufacturing also apply to lean maintenance.

These tools form the foundation of lean maintenance and include:

The 5S Process

5s refers to five activities for organizing the workplace. When implemented, they deliver improved overall efficiency, storage and maintenance. Each "S" is a Japanese word that means:

Sort (Seiri) – Sort through the items at a location and remove any unnecessary objects. This improves safety and reduces the time spent looking for what's needed.

Set in order (Seiton) – Rearrange the workplace so needed items are stored optimally and are easy to find.

Shine (Seiso) – Sweep, clean and inspect the workplace and any machinery. This prevents deterioration, improves safety and creates a pleasant environment.

Standardize (Seiketsu) – Establish schedules and procedures for repeating the first three "S" activities.

Sustain (Shitsuke) – Also described as "do without being told." At this stage, workers are self-disciplined enough to continue and sustain the improvement process without continuously being told what to do.

Just in Time (JIT)

Just in time is a concept commonly used in reference to inventory. Companies use this strategy to reduce waste during the production process by receiving goods into their stock only when needed.

In lean maintenance, operators aim to predict repairs as accurately as possible. Repairs should never be done too soon or too late and all necessary spare parts should be available when due. In other words, monitor equipment and purchase parts "just in time" for the next maintenance task.

Elimination of the Seven Deadly Wastes

Reduce the steps in the process that add no value by eliminating the seven deadly wastes or "TIM WOOD."

Transportation – Moving items and tools from one place to another unnecessarily.

Inventory – Allowing activities, such as work orders and job requests, to pile up.

Motion – Undesirable and avoidable movement due to poor workplace design and layout.

Waiting – Delays and idle time as a result of downtime, parts shortage, slow approval, etc.

Overprocessing – Doing work that the customer will not pay for or does not require.

Overproduction – Producing more than the required quantity of a good "just in case."

Defects (Rework) – Resources wasted while correcting repair or servicing mistakes.

Total Productive Maintenance (TPM)

Total productive maintenance is a hands-on, system-wide and proactive approach to maintenance that lies at the very root of lean maintenance. Ideally, TPM should be already implemented and operational before an organization makes plans to adopt and sustain lean maintenance.

Take one of the pillars of TPM, autonomous maintenance, for instance. From top to bottom of the organization, every employee is involved in carrying out routine maintenance on the physical assets they operate daily.

By so doing, the enterprise enjoys the benefits of having a team of multi-skilled technicians, operators and executives all working together to limit incidents of loss, breakdowns and other inconveniences.

Reliability-Centered Maintenance (RCM)

Reliability-centered maintenance is another proactive maintenance strategy used to monitor physical assets in their present operating condition and predict their maintenance requirements.

Since statistics indicate that about 70 percent of equipment failures are self-induced, maintenance engineers need to discover the causes of these failures. Thereafter, they can recommend preventive maintenance actions.

Planning for Lean Maintenance

The following items can help guide the preparatory stages for implementing lean maintenance.

- **Proactive maintenance:** Proactive, rather than reactive, maintenance should be already in place and operational.
- **A work order system:** This would capture all work assigned with details about maintenance schedules and job status. When managed within a

computerized maintenance management system (CMMS), work orders are invaluable for quick access to information, especially equipment history.

- **A CMMS:** As a minimum, a CMMS should perform the following functions: budget and cost, work order management, planning and scheduling, spares management, reporting and labor management.
- **An updated asset inventory:** This will help ensure that no machine is overlooked during maintenance planning.
- **Training and empowerment of operators:** Both are required before handing over machines to them. Training and empowerment should be thoroughly exhausted as part of TPM implementation.

A Few Benefits of Lean Maintenance

Implementing lean maintenance delivers numerous benefits. Among them are:

Avoiding waste – A typical example is using the JIT concept to avoid keeping expensive inventory longer than necessary.

Reducing inefficient activities – Inefficient activities include running around looking for tools and shutting down equipment for maintenance without ensuring the resources for servicing are available beforehand.

Eliminating urgency – Frantic and urgent repairs are reduced to the barest minimum.

Minimizing the cost of maintenance – When the shutdown of critical equipment for maintenance is well planned, it reduces the amount of production time lost.

Common Challenges with Using Lean Maintenance

Organizations typically face two main challenges when implementing a lean maintenance strategy.

The first is expense. The up-front costs of some aspects of lean maintenance, for example implementing RCM, may be considerable. As such, it will take some time before reaping the benefits.

The second challenge is resistance to change. Some resistance to the new way of doing things should be expected. However, this resistance has to be carefully managed to ensure success of the entire process.

Conclusion

Lean maintenance and the benefits it promises are achievable. But, there is significant preparation that should be in place beforehand so it doesn't become another wasted endeavor.

A major part of that preparation should focus on adopting the TPM and RCM culture well in advance before attempting to apply lean maintenance.



Bryan Christiansen is founder and CEO at Limble CMMS. Limble is a mobile first, modern, and easy to use CMMS software that takes the stress and chaos out of maintenance by helping managers organize, automate and streamline their maintenance operations. www.limblecmms.com



Powered by **Prescient**

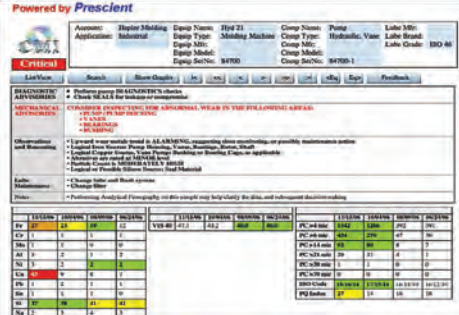

Fluid (Oil) Analysis Program Manager

Prescient™

AI-Infused Fluid Analysis Evaluation and Management

- ✓ Spot-on Data Assessment
- ✓ Strong Maintenance Advisories
- ✓ Tailored to Your Unique Application



HAVE YOU BROUGHT THE POWER OF *The Uptime Elements into Maximo?*

Banetti

THAT'S WHAT WE DO



Uptime® Elements ©2016-2019, Reliabilityweb.com. All rights reserved.

<http://www.banetti.com>

CHOOSE TO REUSE: ENVIRONMENTAL

BENEFITS OF RECONDITIONED

SF₆

Danielle White

When it comes to medium and high voltage circuit breakers, there is no better electrical insulator than sulfur hexafluoride (SF₆). The manufactured gas is most commonly used to fill circuit breakers within utility substations to prevent and quench arcing events. Transmission substations transfer high voltage power to distribution substations, which subsequently disperse the incoming electricity to lower voltages suitable for consumers on power grids. Both transmission and distribution circuit breakers are vulnerable to arcing events, which can be triggered by power surges, partial discharges and lightning strikes.

SF₆'s impeccable dielectric strength, arc quenching capabilities and resilience to remain thermally stable are just a few reasons why this gas has remained a staple in the transmission and

distribution (T&D) industry. It has been the preferred gas in switchgears for over 50 years.

Two Types of SF₆

Sulfur hexafluoride is available in two types: virgin SF₆ and reconditioned SF₆. Virgin sulfur hexafluoride is generated overseas in Europe and Asia. Its production is a known source of green-

house gas emissions. According to the *Environmental Science & Technology Report*, SF₆ production in China contributed to 10 percent of gas emissions from the country between 1990 and 2010. This is a huge environmental concern due to the long atmospheric lifespan of SF₆ – an astounding 3,200 years.

Moreover, virgin SF₆ impacts climate change as the gas is highly potent. SF₆ has a global warm-

“**...Reconditioned SF₆ is 100 percent recyclable,** which provides an ecological benefit in the reduction of the industry’s carbon footprint”



Figure 1: SF₆ gas separator, which uses a cryogenic process to recondition contaminated SF₆ gas to >99.99% purity

ing potential (GWP) of 22,800. To help put this into perspective, one pound of virgin SF₆ released into the atmosphere has the same effect as 11 tons of carbon dioxide. With the results of multiple research studies regarding the effects of emissions and by-products, it is surprising to learn that some original equipment manufacturers (OEMs) for circuit breakers and electrical utilities are proponents for utilizing only virgin SF₆.

Reconditioned SF₆, on the other hand, offers overwhelming benefits. After undergoing the correct cleansing/separation process, used SF₆ can be transformed to a new condition and offers the following advantages:

- Unlike air and oil – the first used insulating mediums in the industry – reconditioned SF₆ is 100 percent recyclable, which provides an ecological benefit in the reduction of the industry’s carbon footprint.
- An alternative to product disposal without increasing budgetary costs.

Additionally, virgin SF₆ poses a risk to the environment if emitted into the atmosphere. Preventing SF₆ emissions is possible with properly trained staff, reliable maintenance equipment and utilization of reconditioned gas.

Although SF₆ production is unavailable in the United States, there are a few suppliers who can provide reconditioned gas at premium grades that exceed the necessary standards for use in gas insulated equipment (GIE). Sourcing SF₆ locally can help greatly reduce the carbon footprint in North America without compromising the product quality or durability of GIE.

SF₆ Reconditioning Programs

Generally, contaminated SF₆ goes unnoticed until a breaker fault is reported or during routine maintenance. SF₆ that does not meet International Electrotechnical Commission (IEC) and Institute of Electrical and Electronic Engineers (IEEE) standards is usually set aside for disposal. A more cost-effective and eco-friendly option is to reuse by participating in an SF₆ reconditioning pro-

gram. These programs guarantee locally available product to the end user while being mindful to the environment. Choosing to recondition gas in place of disposal discourages importation of virgin gas and, in turn, helps reduce SF₆ emissions from not only the creation process, but from exhaust or fuel emissions that take place during transport to North America.

An additional advantage for sourcing reconditioned SF₆ is cost savings. Virgin gas is typically sold at a premium and guarantees a greater than 99.99 percent purity rating. What many users do not realize is that technology is currently available that can separate by-products and air from tainted SF₆. The filtration process makes it possible for used SF₆ to reach federal and international standards for tech grade gas, all at a lower cost. This cost savings does not compromise quality. Whether your SF₆ supply is restocked with greater than 99.9 percent or 5/9 gas (99.999 percent), the result is the same: a circuit breaker filled with a reliable product that requires minimal maintenance (provided best handling techniques are practiced).

Alternative Gases

As of late, alternative gases are a hot topic in the electrical sector. The negative impact of SF₆ emissions has pushed the industry to develop an alternate medium that is much safer for the environment. While implementing a substitute gas is possible, there are still various factors that make the elimination of SF₆ impractical.

The most notable alternative gases are comprised of gas mixtures. These special formulas require a special housing different from SF₆ com-



Figure 2: Analysis equipment measures purity and contamination levels in SF₆ gas



Figure 3: Cylinders used to store SF₆ gas

partments, necessitating a complete overhaul of T&D grids across North America. Most importantly, very little research has been completed regarding procedures for handling alternative gases that have been exposed to arcs. There are no known methods on how to recycle the gas mixtures for repeated use.

Conclusion

From a technological view, there are no significant differences in the makeup of engineered virgin SF₆ and reconditioned SF₆ that has undergone a cryogenic process to remove by-products. Circuit breaker manufacturers and electrical utilities should consider the value of choosing to re-use and eliminate the specification for virgin gas in operational and maintenance procedures. The cultivation of alternative gases does show promise for the electrical industry's future, however, further examination of the by-products, maintenance procedures and recycling capabilities is needed before discounting SF₆ completely.

Reusing properly treated SF₆ removes the need for generating new product and, more importantly, helps lower the carbon footprint in the United States. As long as there is an option to re-use, there are no sound reasons for using virgin gas in circuit breaker applications. For now, reconditioned SF₆ is the alternative gas solution.

References

1. Hu Jianxin, et al. "Sulfur Hexafluoride (SF₆) Emission Estimates for China: An Inventory for 1990-2010 and a Projection to

- 2020." *Environmental Science & Technology*, April 2013, Vol. 47, Issue 8, pp 3848–3855. [https://folk.nilu.no/~fang/Publication/Fang-2013-EST-Sulfur%20hexafluoride%20\(SF6\)%20emission%20estimates%20for%20China%20an%20inventory%20for%201990-2010%20and%20a%20projection%20to%202020.pdf](https://folk.nilu.no/~fang/Publication/Fang-2013-EST-Sulfur%20hexafluoride%20(SF6)%20emission%20estimates%20for%20China%20an%20inventory%20for%201990-2010%20and%20a%20projection%20to%202020.pdf)

2. European Fluorocarbons Technical Committee (EFCTC). *Products & Applications of Sulfur Hexafluoride (SF6)*: <https://www.fluorocarbons.org/products-applications-sulphur-hexafluoride-sf6/>
3. Ponchon, Philippe. "G³ – In the Air." *Think Grid*. December 22, 2017. <http://www.think-grid.org/g3-in-the-air>
4. Nyberg, Dave. "3M" Novac" Dielectric Fluids SF₆ Alternatives for Power Utilities." Workshop for SF₆ Emission Reduction Strategies, January, 2017. https://www.epa.gov/sites/production/files/2017-02/documents/nyberg_presentation_2017_workshop.pdf
5. United States Environmental Protection Agency. *Electric Power Systems Partnership*: <https://www.epa.gov/f-gas-partnership-programs/electric-power-systems-partnership>



Danielle White is the Account Manager for DILO Company, Inc.'s Canadian customer base and Marketing Associate. Together with her team, Danielle's focus is to spread safe SF₆ handling practices and awareness regarding SF₆ emissions. www.dilo.com

GO MAXIMO

Users Conference
EXTENDING MAXIMO

April 1st - 3rd, 2019

Royal Sonesta Hotel
2222 West Loop S, Houston, TX 77027

For more details visit: www.gomaximo.org



THIS IS THE ONLY CONFERENCE IN THE INDUSTRIAL WORLD THAT DEALS EXCLUSIVELY WITH ELECTRICAL SYSTEM RELIABILITY. DON'T MISS IT.



A reliability journey
awaits you!

Several leaders in the reliability world have told us that this is the only event of its kind. Join us in Austin on September 17–19, and be a part of this vital conversation!

PowerSummit19.org

 Electric Power
Reliability Summit¹⁹

FOR PRACTITIONERS.
BY PRACTITIONERS.



CONGRATULATIONS TO THE NEWEST CERTIFIED RELIABILITY LEADERS

Mohammed Abdulqader
 Mansour AL-Shehri
 David Albrice
 Kirk Alcock
 Terry Alexander
 Sami Alghamdi
 Marcelo Alkmin da Costa
 William Alleshouse
 Aziz Alshehri
 Maarouf AlZahrani
 Michael J. Anderson
 Chip Angus
 Chris Arndt
 Arthur Ayres de Almeida
 Robert Ballard
 Jason Barcelo
 Randall Bennett
 David Berube
 Matthew Bosco
 Eric Boyd
 Michelle Brenner
 Terence Brown
 Brad Burgan
 Darryl Cain
 Martín Carrillo Martínez
 Paul Casto
 Jody Connick
 Jim Connors
 Jose R. Contreras M.
 Naresh Copeland
 Howard Rogers Corley Jr.
 Robert F. Cotter

Freddy Couch
 Stephen R. Craft
 Brad Cunic
 Meg Davis
 Lisa Deckard
 Oscar Delgado
 Derek Dempsey
 Alex Desselle
 Liza Donath
 John Doss
 Victor Edozie
 Muhammad Felemban
 Arquimedes Ferrera Martinez
 Dan Flores
 Christian Fogle
 Michael T. Foree
 Mark Forsyth
 Nicolas Fuentes-Zulvaga
 Robin Fulk
 Michael Gerbracht
 Chris Gerold
 Thomas Goodyer
 Jerome Googeg
 Edmund Graves
 Michael Hansen
 Joseph Hartzell
 Felipe Andres Henao Vargas
 Michael Holloway
 Tara Holwegner
 Tracy Hrebik
 Michael G. Hung
 Richard Jansen
 Jake Janzen
 Ahmad Jaradat
 Jose Jimenez Sanchez
 April Johnson
 Ryan Johnson
 Ross Johnston
 Kevin Kay
 Jeremy Kays
 Nick Keith

Sharib A. Khan
 William Kirkpatrick
 David J. Knisley
 Steven Kraus
 Tom Kuzmicki
 Doris Lee
 Tracy Lee
 Robert Lefebvre
 Greg Litz
 Jaime Lopez
 Cong Luong Nguyen
 Bruce Majer
 Rafael Marrero Carrasquillo
 Doug McCall
 Steven McCall
 Kevin McGehee
 Jason McGinnis
 Michael McLaughlin
 Gabriela Magdalena Mejias
 Aristimuno
 David Meldrum
 Mike Miller
 Matt Min
 Bradford Mitchell
 Rory Monto
 Daniel Moon
 Matthew M. Morris
 Peter Munson
 Blair Myers
 Ryman Navoa
 Jeffrey S. Nevenhoven
 Zachary Newman
 Seth Nicholson
 Robert Niederlander
 Brian Odom
 Kevin Orahood
 Greg Padesky
 George Parada
 Ryan Parker
 Chad Pennings
 Juan Diego Porras-Alvarado

Pedro Alejandro Portillo Caldera
 Jon Prater
 Robert Puzak
 Carlos Eduardo Quintero Roa
 Tim Rautmann
 Pedro Reyes Lopez
 Noah Riojas
 Dean Rizzo
 Lindsey Roby
 Jesse Rothkopf
 Thomas Ruger
 Joel Sadler
 Tom Sanders
 Rocky Schlosser
 Andre Seidenthal
 Christopher Sirak
 Michael N. Smith
 Ron Smith
 Arthur Sorak
 Brandon Spyker
 Bhanu Srilla
 Tate Stratton
 Steven Swafford
 Wesam Taiyar
 Laveryl Vanningen
 Denise Verissimo
 Juan F. Villarreal
 Josiah Vincek
 Andrew Waldron
 Terry Waterman
 Reggie Wesdorp
 Andrew Willis
 Marshall Winterbotham
 Richard J. Wolven
 Terry Wright
 Jason Yancy
 Lynnwood Yates
 Eleonora Zaitseva
 Eric Zaweski
 Matthew J. Zellers



NEXT STEP

UPTIME ELEMENTS

BLACK BELT PROGRAM

blackbelt@reliabilityweb.com

www.maintenance.org

"The Uptime Elements approach provides an excellent foundation for anyone looking to understand how reliability can help move their organization to the next level of performance."

~CRL Workshop Attendee



LEADER

RELIABILITY • CULTURE • LANGUAGE



CERTIFIED RELIABILITY LEADER® WORKSHOP

WORKSHOP OBJECTIVES

- Teach the Uptime® Elements - A Reliability Framework and Asset Management System™
- Guide students to discover what it is to 'BE' a reliability leader

UPCOMING DATES

March 18-22

May 6-9

Sept 30-Oct 4

June 10-14

Nov 11-15

June 25-28

Dec 9-12

reliabilityleadership.com



RELIABILITY LEADERSHIP ZOMBIE APOCALYPSE GAME

Featured at the CRL Workshop. Bring the game to your facility!

For more information, contact: crm@reliabilityweb.com





Q&A

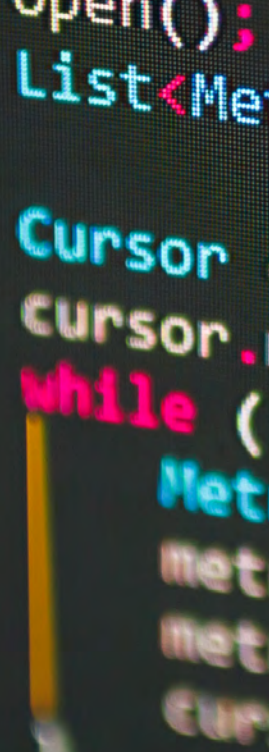

NATASHA RAVINAND

Natasha Ravinand is an author, STEM advocate, writer, and high school student based in Southern California. Natasha has authored a nonfiction book titled *Girls With Dreams*, detailing how childhood implications of gender biases influence the lack of women entering STEM careers. Her voice has reached nearly a million listeners across a variety of platforms and popular media. Natasha is also the founder and President of the nonprofit She Dreams in Code – its aim is to provide and fund coding pathways to minority girls nationwide.

Q: Uptime and its readers are focused on reliability. In your world, what is reliability?

Reliability is being able to perform well on a consistent level. In the technical world, this could be delivering on a user experience, creating a dependable product, or communicating well within a team to reach an objective. From my perspective, it's producing those magical customer experiences where the consistency of the experience builds trust with the customer.

Q: What is the biggest challenge to overcome in the technical and engineering field?

Recruiting top talent is one of the biggest challenges in the technical field. When so much of the technical and engineering workforce is male, Caucasian, or Asian, we see a lack of gender and racial diversity. Less diversity in a technical team generally leads to products that do not appeal to a wide variety of people. In order to advance our innovation, we must attract engineering talent from all genders and races to work on the next generation's products and user experiences.

Q: What is your advice for individuals interested in the engineering field?

I would advise that they start expanding their knowledge and focusing on their curiosity. In the past few years, there has been a huge influx of educational opportunities in technology, both online and offline. If one is interested in pursuing an engineering field, it could be beneficial to learn how to code or basic engineering principles.

Q: What resources are available for young women who are interested in connecting with others who share their same passion and direction?

There are many organizations and online resources that could help young women pursue their passion for computing. One that particularly comes to mind is Girls Who Code. I have had the fantastic privilege of working with this organization in the past; they do a consistently great job at connecting girls across America to coding resources and opportunities. Another resource is Codecademy, which offers free interactive coding lessons in Python, JavaScript and more.



Q: You are a strong, young woman with a passion for computer science and empowering other women in this industry. Who do you admire that inspired you the most?

I admire many people, but one person I especially admire is Grace Hopper. Hopper was a U.S. Navy rear admiral who created the world's first computing compiler. Doing so made coding more accessible and allowed the progress of more technological developments. Hopper was one of the only prominent female computer scientists at the time and, despite pressure from her colleagues and general societal bias, she persevered and changed the world of technology.

Q: Where is one place you've never been that you want to travel to and why?

I would like to travel to Tel Aviv. The city has a vibrant start-up scene and is home to some of the most innovative companies in cryptography, mapping, satellite technology and finance.

Q: If you could have invented one thing, what would it be?

I would have liked to have created SpaceX because I think the work the company is doing in the realm of space transportation will revolutionize the way we travel in the future.

Q: What books do you recommend?

I would recommend *Innovative State: How New Technologies Can Transform Government* by Aneesh Chopra, *Blink: The Power of Thinking Without Thinking* by Malcolm Gladwell, and *The Upstarts: How Uber, Airbnb, and the Killer Companies of the New Silicon Valley Are Changing the World* by Brad Stone.



WIRAM

Women in Reliability
and Asset Management

KEYNOTE PRESENTATION

NATASHA RAVINAND

*Tomorrow's Technical World: How Women
are Essential in Engineering Our Future*

May 6, 2019 • 4:30pm

www.reliabilityconference.com



Can I Find It and Fix It Before It Fails? YES

Did you know that only 8 – 22% of asset failures are attributed to age of the asset? 78 - 92% of the failures happen randomly and will not be found by calendar based maintenance schedules.

IRISS is a global leader in condition based maintenance solutions to help organizations safely and efficiently perform electrical inspections on energized assets. Our unique solutions include:

- Maintenance Inspection Windows (Infrared or Infrared/ Ultrasound Combinations)
- Handheld Ultrasound Inspection Devices and Software
- Wireless Temperature Monitoring
- Intelligent Asset Tagging Solutions
- Customized Inspection Windows (any size, shape and even color match)
- Certified Training Courses in Infrared and Ultrasound Inspection Techniques

Make IRISS your 2019 condition based maintenance partner so your company can reduce risk while saving time and money.

**Learn More at iriss.com or
(941) 907-9128**



THE MAKERS OF
OPTALIGN®
AND
ROTALIGN®

db PRÜFTECHNIK

ROTALIGN® touch rocks!

Often Copied, Never Matched!

Save time, effort, and cost with the most accurate laser alignment system on the market: the ROTALIGN touch



- *Single-laser sensALIGN technology*
- *In-situ cardan shaft alignment*
- *Real-time simultaneous multicoupling measurement*
- *Live Trend*
- *intelliSWEEP, vertiSWEEP and Live Trend analysis*

www.rotalign-touch.rocks

LUBRICATION ENGINEERS, Inc.

Uptime HERO



30,000 HRS

Meet the Air Compressor That Went 30,000 hours with the Same Oil

That's right – in 30,000 hours of operation, no oil change and no lubrication-related downtime. In fact, the oil is nearly ageless, providing the same asset protection today as the day it was added. That's nearly four times longer than the OEM-recommended interval for this compressor.

How'd we do it? By Implementing these two simple solutions:

- 1 Xamine™ Oil Analysis
- 2 Multilec® Industrial Oil

What about you?

Apply these solutions to your equipment and start tracking the value to your organization of extreme uptime, extended oil drains, reduced maintenance labor, and reduction of costly unplanned part replacement. Truly heroic stuff.

Read more about our air compressor success story at www.lelubricants.com/air-compressor-lubricants.html and then contact us to get started. All of these solutions – and many more – are available on the LE website or through our local lubrication consultants.



www.LElubricants.com • 800-537-7683
info@LE-inc.com • Fort Worth, TX • Wichita, KS
LE operates under an ISO 9001 Certified Quality System.

